

SPiRiT[®]



GAS GRILL

LP Gas Grill Owner's Guide

210/310

#89307



**YOU MUST READ THIS OWNER'S GUIDE
BEFORE OPERATING YOUR GAS GRILL.**

⚠ DANGER

If you smell gas:

- 1. Shut off gas to the appliance.**
- 2. Extinguish any open flames.**
- 3. Open lid.**
- 4. If odour continues, keep away from the appliance and immediately call your gas supplier or your fire service.**

Leaking gas may cause a fire or explosion, which can cause serious bodily injury or death, or damage to property.

⚠ WARNING

- 1. Do not store or use petrol or other flammable vapours and liquids in the vicinity of this or any other appliance.**
- 2. A gas supply cylinder not connected for use should not be stored in the vicinity of this or any other appliance.**

⚠ WARNING: Follow all leak-check procedures carefully in this manual before operating barbecue. Do this even if barbecue was dealer-assembled.

⚠ WARNING: Do not ignite this appliance without first reading the BURNER IGNITION sections of this manual.

**INFORMATION FOR THE INSTALLER:
This manual must remain with the owner, who should keep it for future use.**

OUTDOOR USE ONLY.

**CE :845BR-0045
ID: 0845**

WARNINGS

⚠ DANGER

Failure to follow the Dangers, Warnings and Cautions contained in this Owner's Manual may result in serious bodily injury or death, or in a fire or an explosion causing damage to property.

⚠ WARNINGS

- ⚠ Follow regulator connection instructions for your type of gas grill.
- ⚠ Do not store a spare or disconnected gas supply cylinder under or near this barbecue.
- ⚠ Do not put a barbecue cover or anything flammable on or in the storage area under the barbecue.
- ⚠ Improper assembly may be dangerous. Please carefully follow the assembly instructions in this manual.
- ⚠ After a period of storage and/or non-use, the Weber Gas Barbecue should be checked for gas leaks and burner obstructions before use. See instructions in this manual for correct procedures.
- ⚠ Do not use a flame to check for gas leaks.
- ⚠ Do not operate your Weber® gas barbecue if there are any leaking gas connections.
- ⚠ Flammable materials should not be present within approximately 60 cm of the barbecue.
- ⚠ Your Weber® gas barbecue should not be used by children. Accessible parts of the barbecue may be very hot. Keep young children away while it is in use.
- ⚠ Exercise caution when using your Weber® gas barbecue. It will be hot during cooking or cleaning, and should never be left unattended, or moved while in operation.
- ⚠ If the burners should go out during cooking, turn off all gas valves. Open the lid and wait five minutes before attempting to re-light the gas flame, while observing the "Ignition" instructions.
- ⚠ Do not use charcoal, briquettes or lava rock in your Weber® gas barbecue.
- ⚠ While cooking, never lean over the open barbecue or place hands or fingers on the front edge of the cookbox.
- ⚠ Should an uncontrolled flare-up occur, move food away from the flames until flaring subsides.
- ⚠ Should a grease fire occur, turn off all burners and leave lid closed until fire is out.
- ⚠ The Weber® gas barbecue should be cleaned thoroughly at regular intervals.
- ⚠ When cleaning valves or burners, do not enlarge orifices or ports.
- ⚠ Liquid propane gas is not natural gas. The conversion or attempted use of natural gas in a LP gas unit is dangerous and will void your warranty.
- ⚠ A dented or rusty gas supply cylinder may be hazardous and should be checked by your gas supplier. Do not use a gas supply cylinder with a damaged valve.
- ⚠ Even though your gas supply cylinder may appear to be empty, it might still contain gas. The cylinder should be transported and stored accordingly.
- ⚠ Under no circumstances should you attempt to disconnect the gas regulator or any gas fitting while your barbecue is in operation.
- ⚠ Use heat-resistant barbecue mitts or oven gloves when operating barbecue.
- ⚠ Do not use this barbecue unless all parts are in place. The unit must be properly assembled according to the instructions outlined in the "Assembly" instructions.
- ⚠ Do not build this model of grill in any built-in or slide-in construction. Ignoring this warning could cause a fire or an explosion that may damage property or cause serious bodily injury or death.

TABLE OF CONTENTS

WARNINGS	2	MAINTENANCE	22
TABLE OF CONTENTS	3	CLEANING	22
EXPLODED VIEW 210	4	PRESERVE YOUR STAINLESS STEEL	22
EXPLODED VIEW LIST 210	5	WEBER® SPIDER/INSECT SCREENS	22
EXPLODED VIEW 310	6	BURNER TUBES CLEANING OR REPLACEMENT	23
EXPLODED VIEW LIST 310	7	ELECTRONIC CROSSOVER® IGNITION SYSTEM OPERATIONS	24
WARRANTY	8	ANNUAL MAINTENANCE	24
GENERAL INSTRUCTIONS	8	MEMO	25
STORAGE	8		
OPERATING	8		
GAS INSTRUCTIONS	9		
SAFE HANDLING TIPS FOR LIQUID PROPANE GAS CYLINDERS	9		
CYLINDER INSTALLATION LOCATION OPTIONS	10		
INSTALLING THE CYLINDER	11		
PREPARE TO CONNECT THE LP CYLINDER	12		
CONNECTING THE LIQUID PROPANE CYLINDER	13		
LEAK-CHECK PREPARATION	13		
CHECK FOR GAS LEAKS	14		
REFILLING THE LIQUID PROPANE CYLINDER	16		
RECONNECT THE LIQUID PROPANE CYLINDER	16		
BEFORE USING THE GRILL	17		
SLIDE-OUT GREASE TRAY AND DISPOSABLE DRIP PAN	17		
ELECTRONIC IGNITER INSPECTION	17		
HOSE INSPECTION	17		
MAIN BURNER IGNITION & USAGE	18		
MAIN BURNER IGNITION	18		
TO EXTINGUISH	18		
MAIN BURNER MANUAL IGNITION	19		
TO EXTINGUISH	19		
GRILLING TIPS & HELPFUL HINTS	20		
PREHEATING	20		
COVERED COOKING	20		
DRIPPINGS AND GREASE	20		
FLAVORIZER® SYSTEM	20		
TROUBLESHOOTING	21		

EXPLODED VIEW 210

Spirit_210_LP_Euro_122910

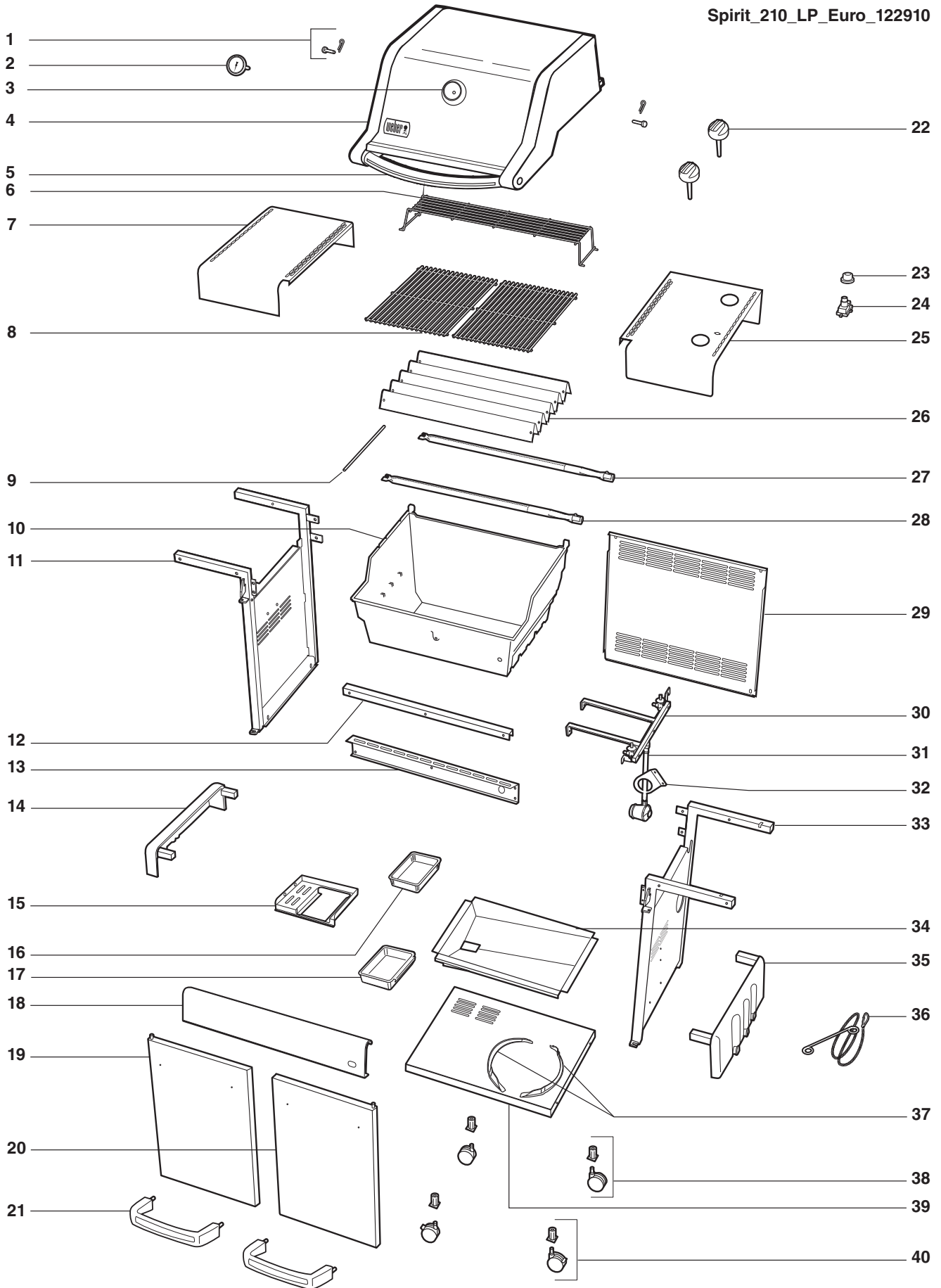

EXPLODED VIEW LIST 210

- | | | |
|-------------------------|-------------------------|----------------------------|
| 1. Shroud Hardware | 16. Disposable Drip Pan | 31. Hose / Regulator |
| 2. Thermometer | 17. Catch Pan | 32. Hose Retention Bracket |
| 3. Thermometer Bezel | 18. Front Panel | 33. Right Frame Panel |
| 4. Shroud | 19. Left Door | 34. Slide-Out Grease Tray |
| 5. Handle | 20. Right Door | 35. Right Trim Piece |
| 6. Warming Rack | 21. Door Handle | 36. Matchstick Holder |
| 7. Left Side Table | 22. Control Knob | 37. Cylinder Brackets |
| 8. Cooking Grate | 23. Igniter Button | 38. Caster |
| 9. Crossover® Tube | 24. Igniter Module | 39. Bottom Panel |
| 10. Cookbox | 25. Right Side Table | 40. Locking Caster |
| 11. Left Frame Panel | 26. Flavorizer® Bar | |
| 12. Rear Frame Support | 27. Rear Burner Tube | |
| 13. Front Frame Support | 28. Front Burner Tube | |
| 14. Left Trim Piece | 29. Back Panel | |
| 15. Catch Pan Holder | 30. Manifold | |

EXPLODED VIEW 310

Spirit_310_LP_Euro_122910

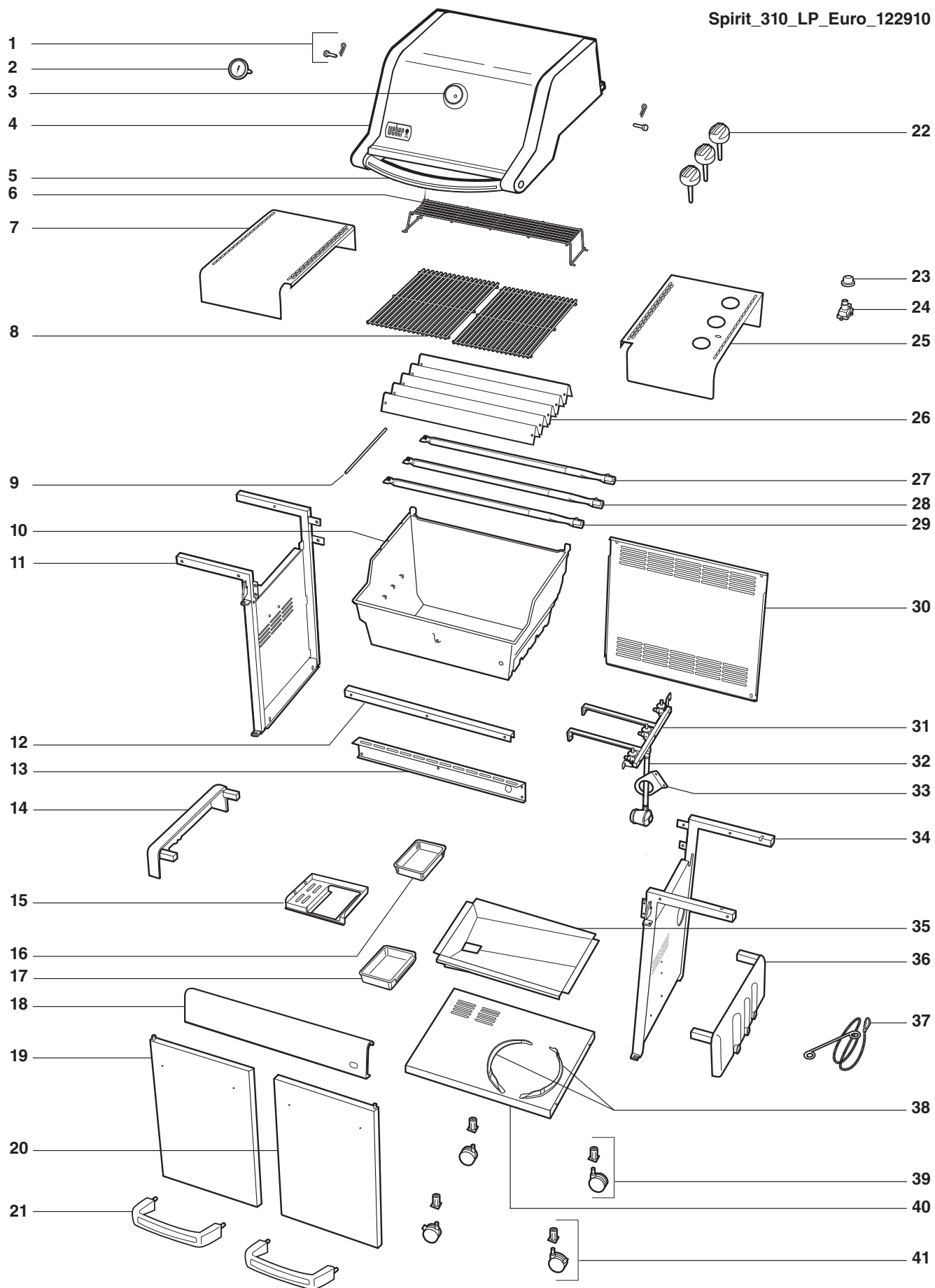

EXPLODED VIEW LIST 310

- | | | |
|--------------------------------|---------------------------------|----------------------------|
| 1. Shroud Hardware | 16. Disposable Drip Pan | 31. Manifold |
| 2. Thermometer | 17. Catch Pan | 32. Hose / Regulator |
| 3. Thermometer Bezel | 18. Front Panel | 33. Hose Retention Bracket |
| 4. Shroud | 19. Left Door | 34. Right Frame Panel |
| 5. Handle | 20. Right Door | 35. Slide-Out Grease Tray |
| 6. Warming Rack | 21. Door Handle | 36. Right Trim Piece |
| 7. Left Side Table | 22. Control Knob | 37. Matchstick Holder |
| 8. Cooking Grate | 23. Igniter Button | 38. Cylinder Brackets |
| 9. Crossover [®] Tube | 24. Igniter Module | 39. Caster |
| 10. Cookbox | 25. Right Side Table | 40. Bottom Panel |
| 11. Left Frame Panel | 26. Flavorizer [®] Bar | 41. Locking Caster |
| 12. Rear Frame Support | 27. Rear Burner Tube | |
| 13. Front Frame Support | 28. Middle Burner Tube | |
| 14. Left Trim Piece | 29. Front Burner Tube | |
| 15. Catch Pan Holder | 30. Back Panel | |

WARRANTY

Weber-Stephen Products LLC (Weber) hereby warrants to the ORIGINAL PURCHASER of this Weber® gas grill that it will be free of defects in material and workmanship from the date of purchase as follows:

Aluminum castings:	25-years (2 years on paint; excludes fading)
Stainless steel shroud:	25-years
Porcelain-enamelled shroud:	25-years
Stainless steel burner tubes:	10-years
Stainless steel cooking grates:	5-years no rust through or burn through
Stainless steel Flavorizer® bars:	5-years no rust through or burn through
Porcelain-enamelled cast-iron cooking grates:	5-years no rust through or burn through
Porcelain-enamelled cooking grates:	3-years no rust through or burn through
Porcelain-enamelled Flavorizer® bars:	2-years no rust through or burn through
Infrared rotisserie burner:	2-years
All remaining parts:	2-years

when assembled and operated in accordance with the printed instructions accompanying it. Weber may require reasonable proof of your date of purchase. THEREFORE, YOU SHOULD RETAIN YOUR SALES RECEIPT OR INVOICE.

This Limited Warranty shall be limited to the repair or replacement of parts that prove defective under normal use and service and which on examination shall indicate, to Weber's satisfaction, they are defective. Before returning any parts, contact the Customer Service Representative in your area using the contact information on our website. If Weber confirms the defect and approves the claim, Weber will elect to replace such parts without charge. If you are required to return defective parts, transportation charges must be prepaid. Weber will return parts to the purchaser, freight or postage prepaid.

This Limited Warranty does not cover any failures or operating difficulties due to accident, abuse, misuse, alteration, misapplication, vandalism, improper installation or improper maintenance or service, or failure to perform normal and routine maintenance, including but not limited to damage caused by insects within the burner tubes, as set out in this owner's manual.

Deterioration or damage due to severe weather conditions such as hail, hurricanes, earthquakes or tornadoes, discolouration due to exposure to chemicals either directly or in the atmosphere, is not covered by this Limited Warranty.

There are no other express warrants except as set forth herein and any applicable implied warranties of merchantability and fitness are limited in duration to the period of coverage of this express written Limited Warranty. Some regions do not allow limitation on how long an implied warranty lasts, so this limitation may not apply to you.

Weber is not liable for any special, indirect or consequential damages. Some regions do not allow the exclusion or limitation of incidental or consequential damages, so this limitation or exclusion may not apply to you.

Weber does not authorise any person or company to assume for it any other obligation or liability in connection with the sale, installation, use, removal, return, or replacement of its equipment; and no such representations are binding on Weber.

This Warranty applies only to products sold at retail.

Visit www.weber.com®, select your country of origin, and register your grill today. ♦

GENERAL INSTRUCTIONS

Your Weber® gas barbecue is a portable outdoor cooking appliance. With the Weber® gas barbecue you can grill, barbecue, roast and bake with results that are difficult to duplicate with indoor kitchen appliances. The closed lid and Flavorizer® bars produce that "outdoor" flavour in the food.

The Weber® gas barbecue is portable so you can easily change its location in your garden or on your patio. Portability means you can take your Weber® gas barbecue with you if you move.

Liquid Propane (LP) gas is quicker to use and gives you more cooking control than charcoal fuel.

- These instructions will give you the minimum requirements for assembling your Weber® gas barbecue. We therefore request that you read them carefully before you use the Weber® gas barbecue.
- Not for use by children.
- Do not connect to natural gas supply (city gas). The valves and orifices are designed exclusively for LP gas.
- Not to be used with charcoal briquettes or lava rock.
- Use only a 3kg-13kg LP gas cylinder.
- In the United Kingdom, this appliance must be fitted with a regulator complying with BS 3016, having a nominal output of 37 millibars. (Supplied with barbecue.)
- Avoid kinking the hose.
- The length of hose must not exceed 1.5 metres.
- We recommend that you replace the gas hose on your Weber gas grill every 5 years. Some countries may have requirements that the gas hose be replaced within less than 5 years, in which case that country's requirement would take precedent.
- Any parts sealed by the manufacturer must not be altered by the user.
- Any modification of the appliance may be dangerous.
- Only a nationally approved low-pressure hose and regulator must be used.
- Replacement pressure regulators and hose assemblies must be those specified by the outdoor cooking gas appliance manufacturer. ♦

STORAGE

- When the Weber® gas barbecue is not being used, turn off the gas supply cylinder valve.
- When storing the Weber® gas barbecue indoors, disconnect the gas supply line. The gas cylinder itself is to be stored outdoors in a well-ventilated place.
- If the gas supply cylinder is not removed from the Weber® gas barbecue, the entire grill and the gas supply cylinder are to be stored in a well-ventilated place outdoors.
- Gas supply cylinders must be stored outdoors in a well-ventilated area out of reach of children. Disconnected gas supply cylinders must not be stored in a building, garage or any other enclosed area. ♦

OPERATING

- ⚠ **WARNING: This appliance is intended for outdoor use only and should never be used in garages and roofed or enclosed porches or verandas.**
- ⚠ **WARNING: The Weber® gas barbecue must never be used under an unprotected combustible roof or overhang.**
- ⚠ **WARNING: The barbecue should not be used when combustible materials are within 60 cm of the top, bottom, back or sides of the grill.**
- ⚠ **WARNING: Your Weber® gas barbecue is not intended to be installed in or on caravans and/or boats.**
- ⚠ **WARNING: When in use, the entire barbecue gets hot. Never leave it unattended.**
- ⚠ **WARNING: Keep electrical mains lead and the fuel supply hose away from heated surfaces.**
- ⚠ **WARNING: Keep the cooking area clear of flammable vapours and liquids, such as petrol, alcohol, etc., and combustible materials.**
- ⚠ **WARNING: Never store an extra (spare) gas supply cylinder near the Weber® gas barbecue.**
- ⚠ **WARNING: This appliance gets very hot. Take special care when children or elderly people are present.**
- ⚠ **WARNING: Do not move the appliance while it is alight.**
- ⚠ **WARNING: Wear protective gloves when using this appliance. ♦**

GAS INSTRUCTIONS

SAFE HANDLING TIPS FOR LIQUID PROPANE GAS CYLINDERS

- Liquid Propane (LP) gas is a petroleum product as are petrol and natural gas. LP gas is a gas at normal temperatures and pressures. Under moderate pressure, inside a cylinder, LP gas is a liquid. As the pressure is released, the liquid readily vapourises and becomes gas.
- LP gas has an odour similar to natural gas. You should be aware of this odour.
- LP gas is heavier than air. Leaking LP gas may collect in low areas and prevent dispersion.
- The LP cylinder must be installed, transported and stored in an upright position. LP cylinders should not be dropped or handled roughly.
- Never store or transport the LP cylinder where temperatures can reach 51°C (too hot to hold by hand - for example: do not leave the LP cylinder in a car on a hot day).
- Treat "empty" LP cylinders with the same care as when full. Even when the LP tank is empty of liquid there still may be gas pressure in the cylinder. Always close the cylinder valve before disconnecting.
- Do not use a damaged LP cylinder. Dented or rusty LP cylinders or LP cylinders with a damaged valve may be hazardous and should be replaced with a new one immediately.
- The joint where the hose connects to the LP cylinder must be leak-tested each time the LP cylinder is reconnected. For example, test each time the LP cylinder is refilled.
- Be sure the regulator is mounted with the small vent hole pointed downward so that it will not collect water. This vent should be free of dirt, grease, insects etc. ♦

REPLACEMENT HOSE AND REGULATOR

Country	Part #
Czech Republic / Latvia / Lithuania / Romania / Slovak Republic / Slovenia	41576
Great Britain	41588
Denmark / Finland / Norway / Portugal / Spain	41619
France	41638
Belgium	41639
Switzerland	41676
Sweden	41677
Austria / Germany	41679
Greece / Italy	41680
Netherlands	41681
Poland	43196
Hungary	43197
Estonia	89169
Turkey	89170

⚠ IMPORTANT NOTICE: We recommend that you replace the gas hose on your Weber gas barbecue every five years. Some countries may have requirements that the gas hose be replaced within less than five years, thus that country's requirement would take precedent.

COUNTRY	GAS TYPE & PRESSURE
Bulgaria, Cyprus, Czech Republic, Denmark, Estonia, Finland, Hungary, Iceland, Latvia, Lithuania, Malta, Netherlands, Norway, Romania, Slovak Republics, Slovenia, Spain, Sweden, Turkey	I ₃ B/P - 30 mbar
Belgium, France, Greece, Ireland, Italy, Luxembourg, Portugal, Switzerland, United Kingdom	I ₃ , - 28-30 / 37 mbar
Poland	I ₃ B/P - 37 mbar
Austria, Germany	I ₃ B/P - 50 mbar

CONSUMPTION DATA

	Propane kW	Butane kW
Spirit® 210	6.9	7.6
Spirit® 310	11.0	11.5
Spirit® 320	11.0	11.5
	Propane g/h	Butane g/h
Spirit® 210	435	547
Spirit® 310	693	828
Spirit® 320	693	828

GAS INSTRUCTIONS

CYLINDER INSTALLATION LOCATION OPTIONS

Pick one of two options to determine the location of the cylinder; install inside the cabinet, or place the cylinder on the ground. The type and size of cylinder you purchase will help determine the cylinder installation location.

Installation Inside Of Cabinet

The LP gas cylinder can be connected inside the grill cabinet as long as the cylinder meets the cylinder size guidelines (1). There are several factors that will determine whether a cylinder may be safely used inside your grill cabinet:

- A) The base of the cylinder must fit between the cylinder brackets and rest flat on the base panel.

Cylinder Dimensions

Height	465 mm maximum
Width	289 mm - (rectangular footprint) or 318 mm (round footprint) maximum

B) Cylinder Capacity

6 kg maximum

Several possible cylinder models are illustrated with approved dimensions (2).

⚠ WARNING: If the LP cylinder that you purchased does not meet the cylinder size requirements, do not attempt to connect the cylinder inside the cabinet. Connect the cylinder outside the cabinet on the right side of the grill. Failure to do so could cause damage to the hose resulting in a fire or explosion, which can cause serious bodily injury or death, and damage to property. ♦

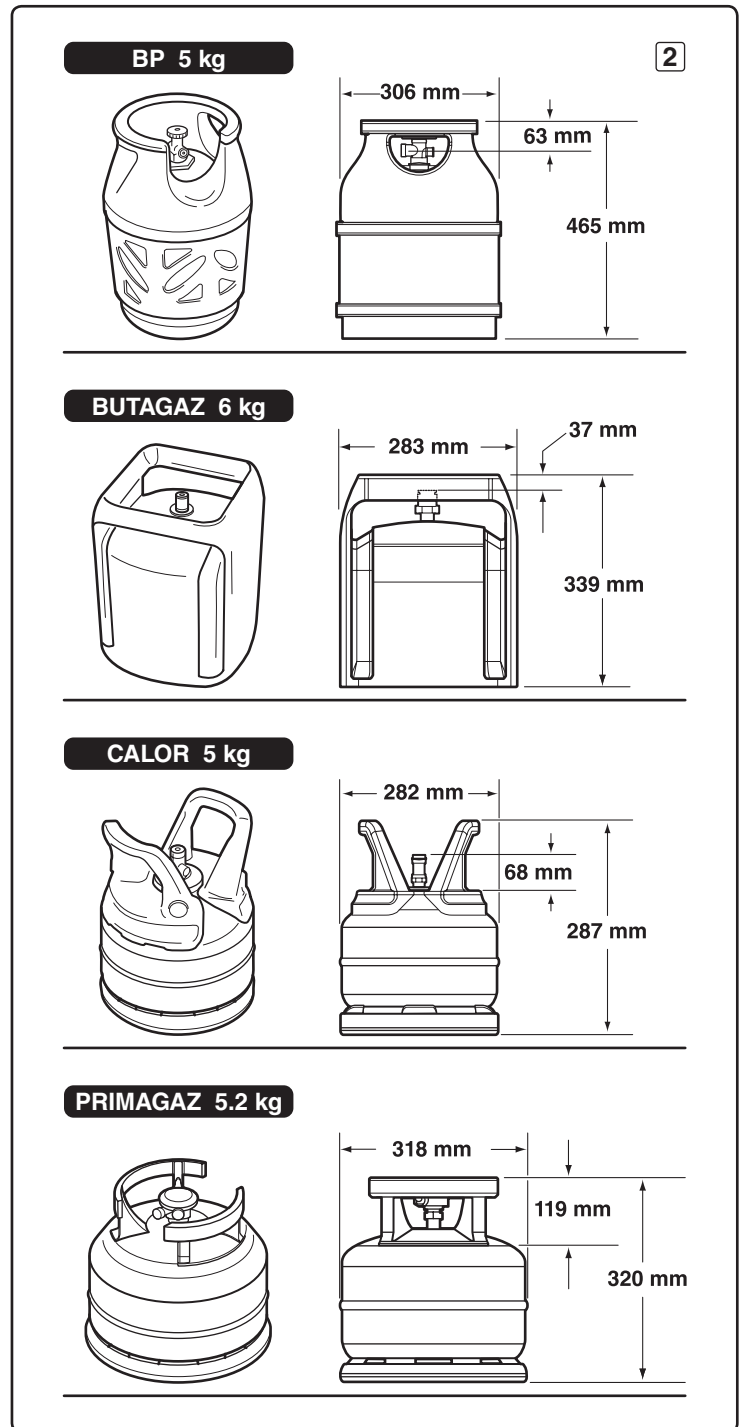
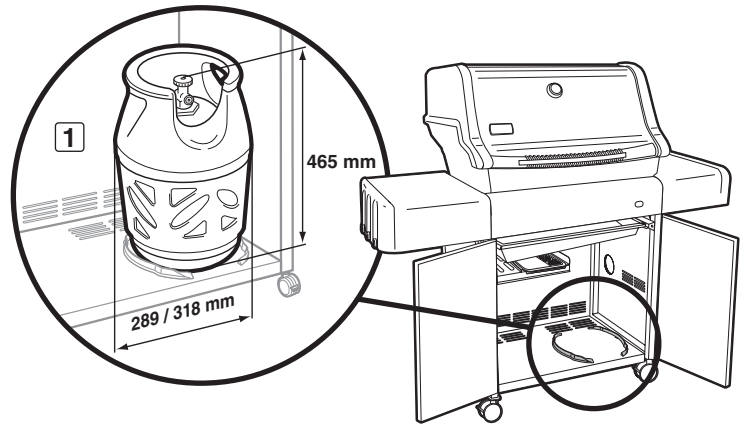

INSTALLING THE CYLINDER

Purchase A Full Cylinder Of Gas From Your Gas Dealer

The cylinder must always be installed, transported and stored in an upright position. Never allow the cylinder to drop or be handled carelessly. Never store the cylinder where temperatures can exceed 51° C (too hot to hold by hand). For example, do not leave the cylinder in your car on hot days. (Refer to: "SAFE HANDLING TIPS FOR LP GAS CYLINDERS").

Cylinder Bracket Installation

You will need: the cylinder brackets (1).

- A) Open the grill cabinet. The cylinder brackets snap into the mounting holes in the base panel as shown in the illustration (2). Insert cylinder bracket tabs into rectangular slots. Secure in place by pivoting brackets down to lock centre tab in place.
- B) Lift and place the cylinder between the cylinder brackets (3) on the base panel. The base of the cylinder must fit between the cylinder brackets (4).
- C) Turn the cylinder so the valve opening faces the front of the barbecue.

Note: Be sure that the cylinder brackets are installed in the base panel and that the base of the cylinder fits within the cylinder brackets.

Installation Outside of Cabinet

If the cylinder you have does not meet the cylinder type and size guidelines place the cylinder on the ground. The cylinder must be placed outside the base cabinet, on the right side of the grill.

- D) Place the cylinder on the ground, outside the base cabinet, on the right side of the grill (5).
- E) Turn the LP cylinder so the opening of the valve is facing the front of the Weber® gas barbecue. ♦

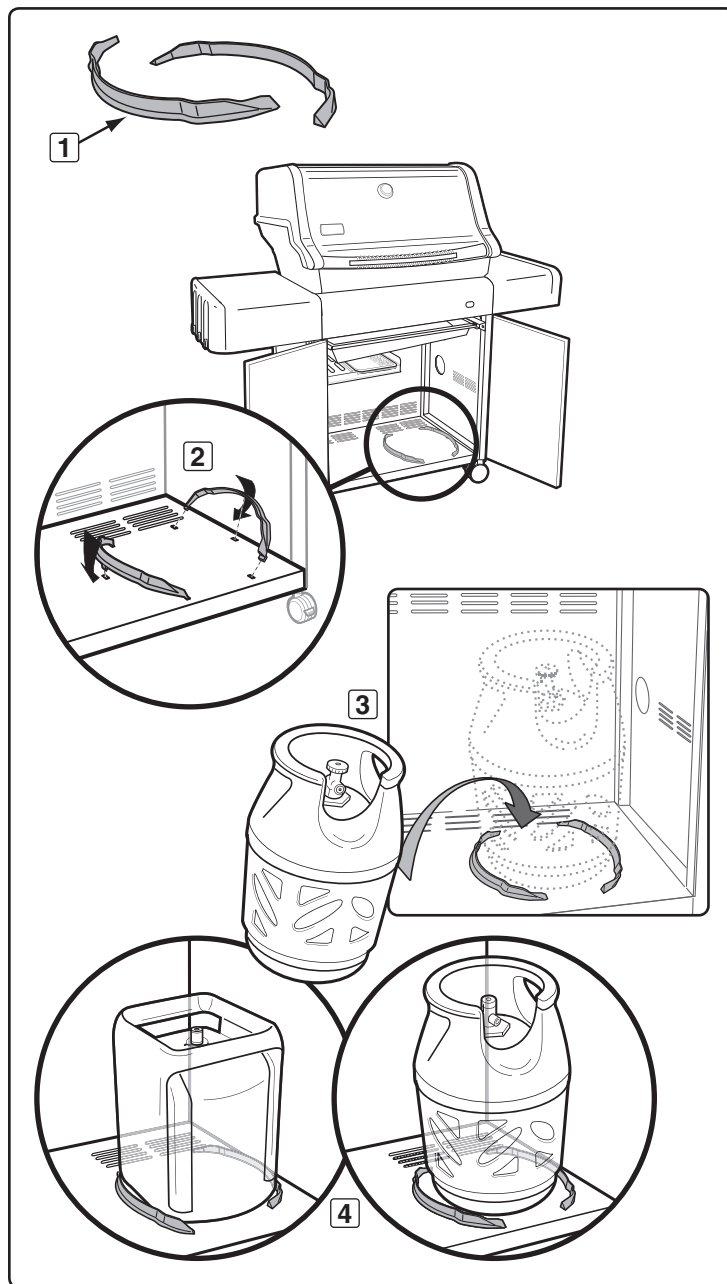

GAS INSTRUCTIONS

PREPARE TO CONNECT THE LP CYLINDER

The regulator must be secured to the side panel with the supplied hose retention bracket.

Installation Inside of Cabinet

- A) Open base cabinet doors.
- B) Pass the regulator hose through the side panel opening to the inside of the base cabinet (1).
- C) Slide the hose retention bracket (2) along hose and through the side panel opening to the inside of the base cabinet.
- D) Position the hose retention bracket on the right inside panel and secure with two Phillips head screws/washer/bolts (3).

⚠ WARNING: The hose must be secured to the side panel with the hose retention bracket. Failure to do so could cause damage to the hose resulting in a fire or explosion, which can cause serious bodily injury or death, and damage to property.

Note: Be sure the cylinder brackets are installed in the base panel and the base of the cylinder fits within the cylinder brackets.

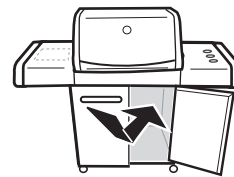
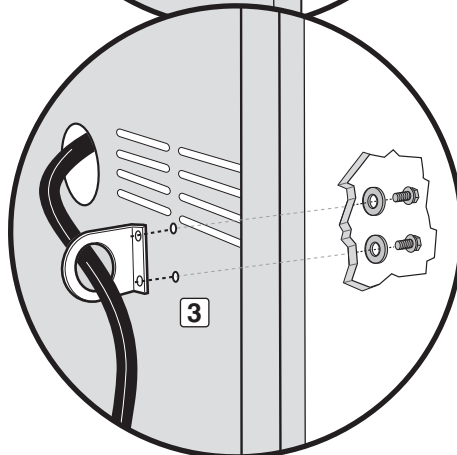
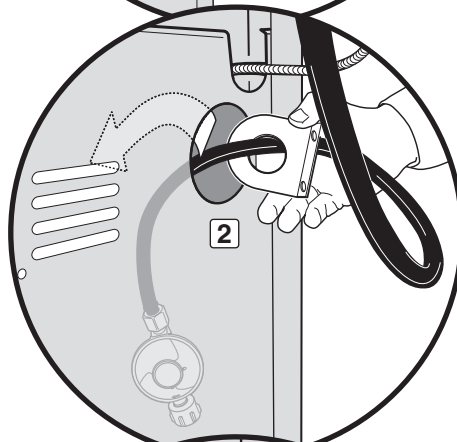
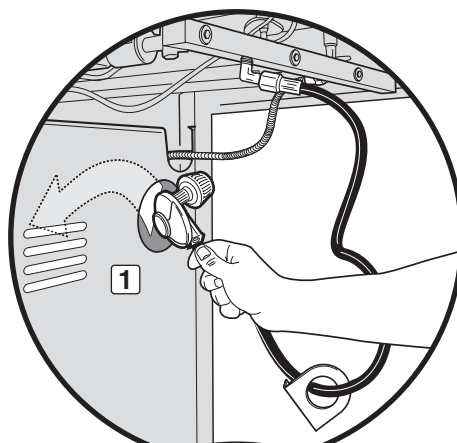

Installation Outside of Cabinet

- E) Position the hose retention bracket on the right outside panel and secure with two Phillips head screws/washer/bolts (4).

⚠ WARNING: The hose must be secured to the side panel with the hose retention bracket. Failure to do so could cause damage to the hose resulting in a fire or explosion, which can cause serious bodily injury or death, and damage to property. ♦

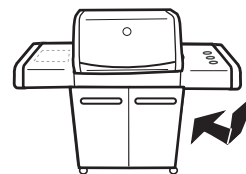
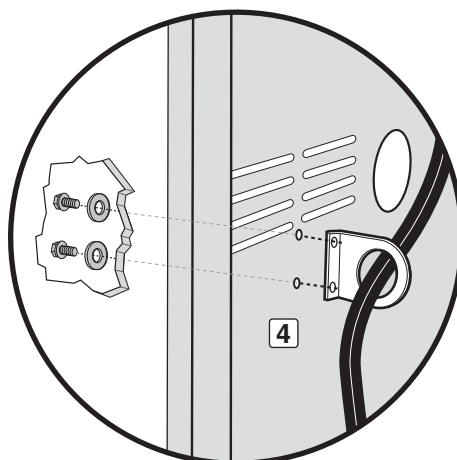

GAS INSTRUCTIONS

CONNECTING THE LIQUID PROPANE CYLINDER

⚠ WARNING: Make sure that the LP cylinder or regulator valve is closed.

A) Connect LP cylinder.

Some regulators push ON to connect, and pull OFF to disconnect, others have a nut that has a left-hand thread that connects to the cylinder valve. Follow one of the specific regulator connection instructions illustrated based on your regulator type.

- a) Screw regulator fitting onto tank turning clockwise (1). Position the regulator so that the vent hole (2) faces down.
- b) Screw regulator fitting onto tank turning anti-clockwise (3) (4).
- c) Make sure regulator lever (5) is in the down/off position. Push regulator down on tank valve until regulator snaps into position (6).
- d) Make sure regulator lever is in the off position. Slide the collar of the regulator up (7). Push the regulator down onto the tank valve and maintain pressure. Slide collar closed (8). If regulator does not lock, repeat procedure. ♦

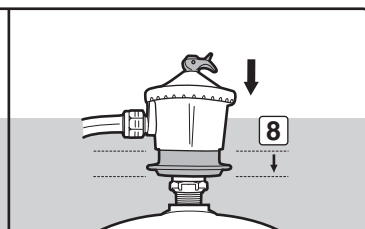
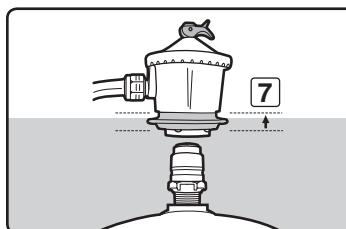
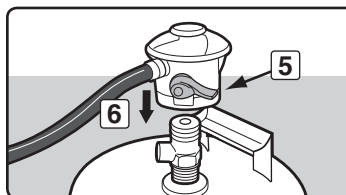
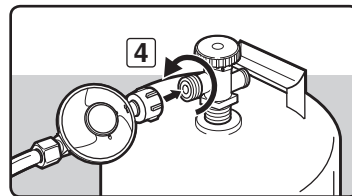
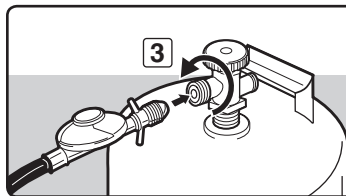
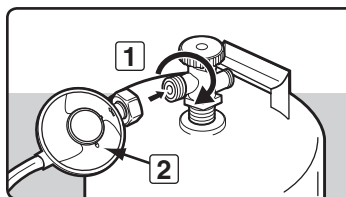

LEAK-CHECK PREPARATION

⚠ WARNING: The gas connections of your gas grill have been factory-tested. We do, however, recommend that you leak-check all gas connections before operating your gas grill.

Remove Control Knobs & Control Panel For Leak Testing

You will need: Phillips screwdriver.

- A) Take off the burner control knobs (1).
- B) Remove screw and washer from back of control panel with a Phillips screwdriver (2).
- C) Remove machine screw from lower left and right side of control panel with a Phillips screwdriver (3).
- D) Tilt the back edge of the control panel up. Carefully lift control panel up and away from frame (4).
- E) Disconnect the igniter wires from the ignition module (5).
- F) Replace control panel when leak check is completed. ♦

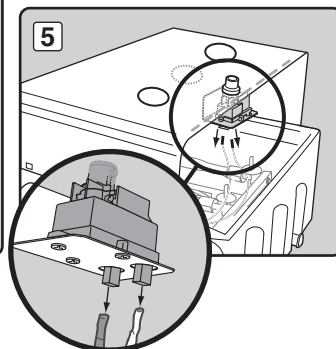
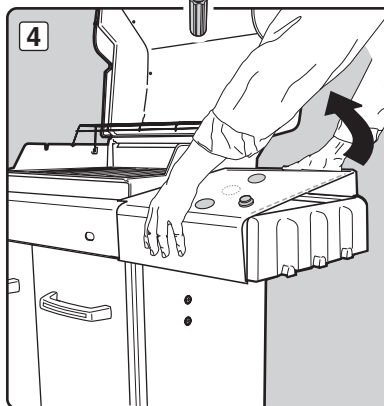
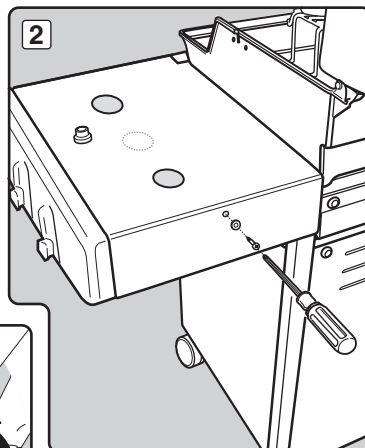
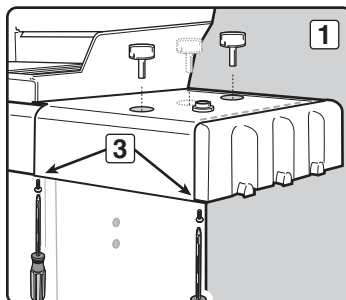

GAS INSTRUCTIONS

CHECK FOR GAS LEAKS

⚠ DANGER

Do not use an open flame to check for gas leaks. Be sure there are no sparks or open flames in the area while you check for leaks. Sparks or open flames will result in a fire or explosion, which can cause serious bodily injury or death and damage to property.

⚠ **WARNING:** You should check for gas leaks every time you disconnect and reconnect a gas fitting.

Note: All factory-made connections have been thoroughly checked for gas leaks. The burners have been flame-tested. As a safety precaution however, you should recheck all fittings for leaks before using your Weber® gas barbecue. Shipping and handling may loosen or damage a gas fitting.

⚠ **WARNING:** Perform these leak checks even if your barbecue was dealer- or shop-assembled.

Note: Since some leak-test solutions, including soap and water, may be slightly corrosive, all connections should be rinsed with water after checking for leaks.

If your grill has a side burner, make sure the side burner is off.

To perform leak checks: open cylinder valve by turning the cylinder valve hand-wheel anti-clockwise.

⚠ **WARNING:** Do not ignite burners when leak checking.

You will need: a soap-and-water solution, and a rag or brush to apply it.

- A) Mix soap and water.
- B) Turn on the cylinder valve using one of the appropriate options based on your cylinder and regulator type.
 - a) Turn cylinder valve anti-clockwise (1) (2) (3).
 - b) Move regulator lever to the up/on position (4).
 - c) Move regulator lever to the on position (5).
- C) Check for leaks by wetting the fitting with the soap-and-water solution and watching for bubbles. If bubbles form, or if a bubble grows, there is a leak. If there is a leak, turn off the gas and tighten the fitting. Turn the gas back on and recheck with the soap-and-water solution. If leak does not stop, contact the Customer Service Representative in your area using the contact information on our website. Log onto www.weber.com.
- D) When leak checking is complete, turn gas supply off at the source and rinse connections with water.

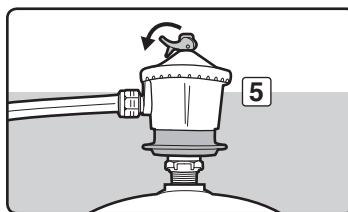
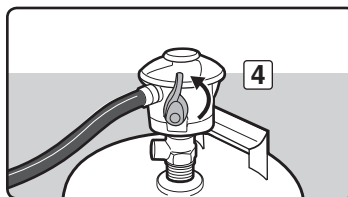
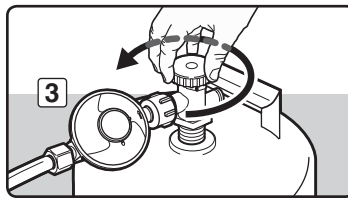
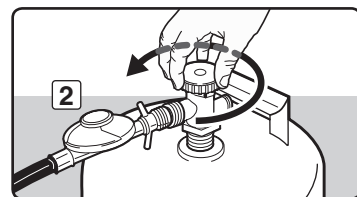
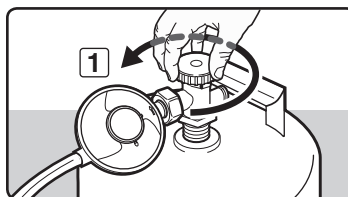

GAS INSTRUCTIONS

Check

E) Hose-to-manifold connection (6).

⚠ WARNING: If there is a leak at connection (6), re-tighten the fitting with a spanner and recheck for leaks with soap-and-water solution. If a leak persists after re-tightening the fitting, turn OFF the gas. DO NOT OPERATE THE GRILL. Contact the Customer Service Representative in your area using the contact information on our web site. Log onto www.weber.com.

F) Regulator-to-cylinder connection (7).

G) Hose-to-regulator connection (8).

H) Valves-to-manifold connections (9).

⚠ WARNING: If there is a leak at connections (7), (8) or (9), turn OFF the gas. DO NOT OPERATE THE GRILL. Contact the Customer Service Representative in your area using the contact information on our web site. Log onto www.weber.com.

When leak checks are complete, turn gas supply OFF at the source and rinse connections with water.

Reinstall Control Panel

You will need: Phillips screwdriver.

- I) Reconnect the igniter wires to the ignition module.
- J) Carefully position control panel down and onto frame.
- K) Reinstall machine screws at lower left and right side of control panel with a Phillips screwdriver.
- L) Reinstall screw and washer onto the back of the control panel with a Phillips screwdriver.
- M) Replace burner control knobs. ♦

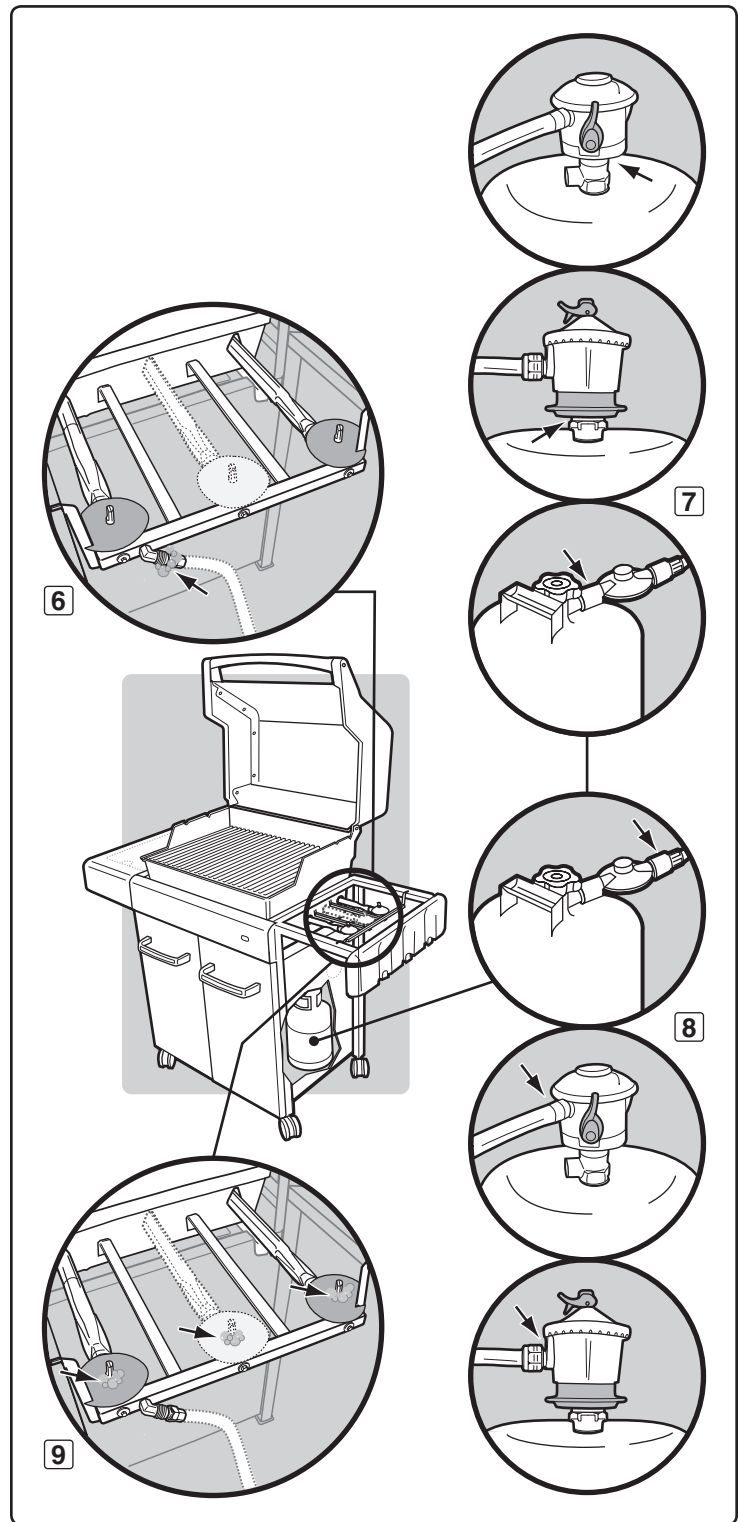

GAS INSTRUCTIONS

REFILLING THE LIQUID PROPANE CYLINDER

We recommend that you refill the LP cylinder before it is completely empty. To refill, take LP cylinder to a "Gas Propane" dealer.

Removal of the gas supply cylinder:

- A) Shut off gas supply and disconnect hose and regulator assembly from the cylinder. Follow one of the specific regulator connection instructions illustrated based on your regulator type.
 - a) Unscrew regulator fitting from tank turning anticlockwise (1).
 - b) Unscrew regulator fitting from tank turning clockwise (2) (3).
 - c) Move regulator lever (4) to the down/off position. Push in on regulator lever until it releases from tank (5).
 - d) Move regulator lever to the off position (6). Slide the collar of the regulator up (7) to disconnect from tank.
- B) Exchange empty cylinder for a full cylinder. ♦

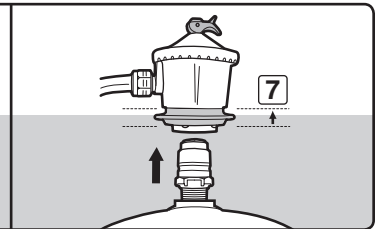
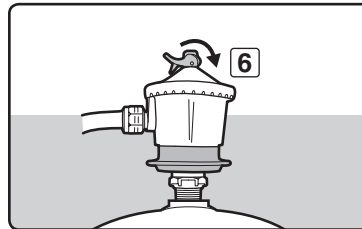
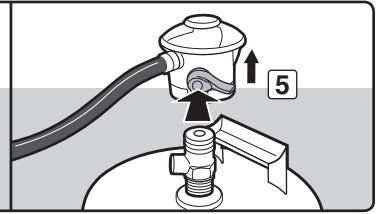
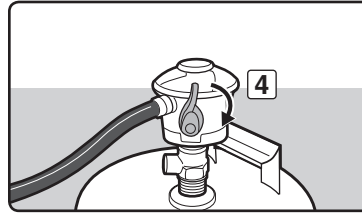
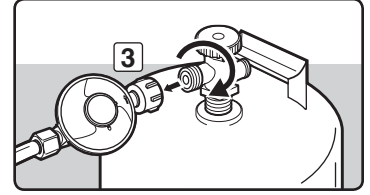
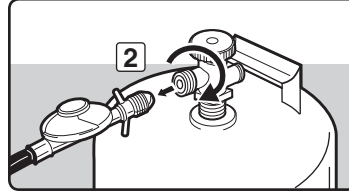
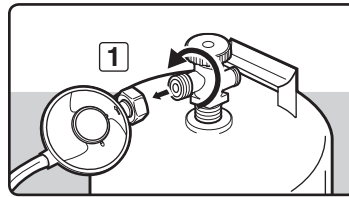

RECONNECT THE LIQUID PROPANE CYLINDER

Refer to "CONNECTING THE LIQUID PROPANE CYLINDER" ♦

BEFORE USING THE GRILL

SLIDE-OUT GREASE TRAY AND DISPOSABLE DRIP PAN

Your grill was built with a grease collection system. Check the slide-out grease tray and disposable drip pan for grease build-up each time you use your grill.

Remove excess grease with a plastic spatula; see illustration. When necessary, wash the grease tray and drip pan with a soap and water solution, then rinse with clean water. Replace the disposable drip pan as needed.

- ⚠ **WARNING: Always check the slide-out grease tray and disposable drip pan for grease build-up before using. Remove excess grease to avoid a grease fire. A grease fire can cause serious bodily injury or damage to property.**
- ⚠ **CAUTION: Do not line the slide-out grease tray with aluminum foil.** ♦

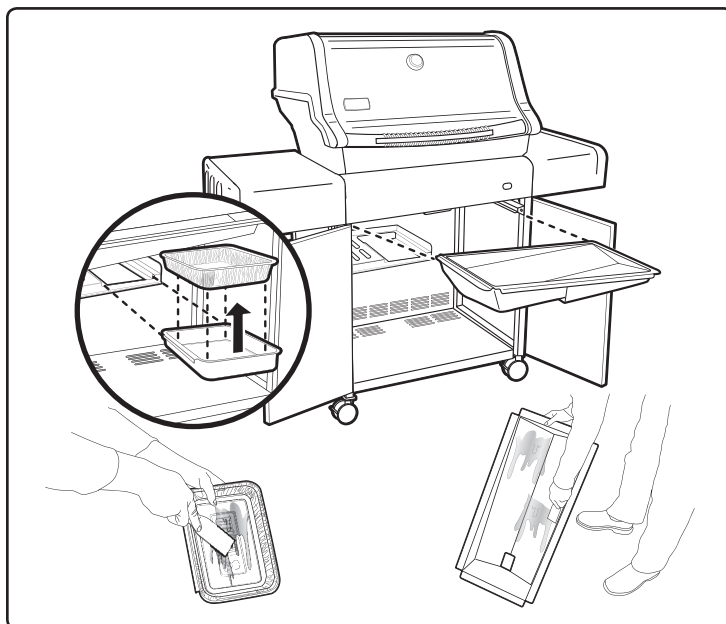

ELECTRONIC IGNITER INSPECTION

Verify that your AA battery (alkaline only) is in good condition and that it is installed correctly (1). Some batteries have a plastic protective wrap around them. This plastic must be removed. Do not confuse this plastic with the battery label. ♦

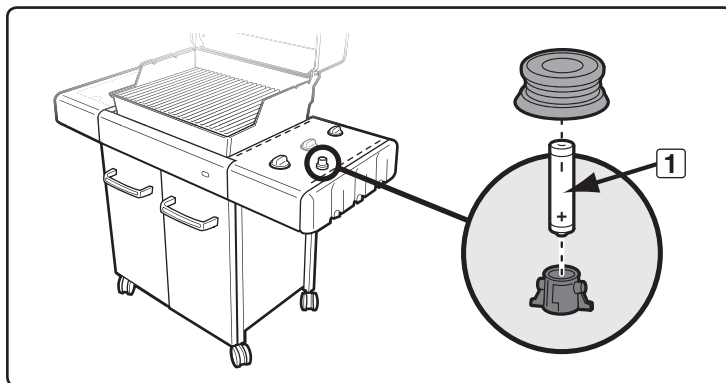

HOSE INSPECTION

The hose should be inspected for any signs of cracking.

- ⚠ **WARNING: Always check hose before using barbecue for nicks, cracking, abrasions or cuts. If the hose is found to be damaged in any way, do not use the barbecue. Replace using only Weber® authorised replacement hose. Contact the Customer Service Representative in your area using the contact information on our web site. Log onto www.weber.com®.** ♦

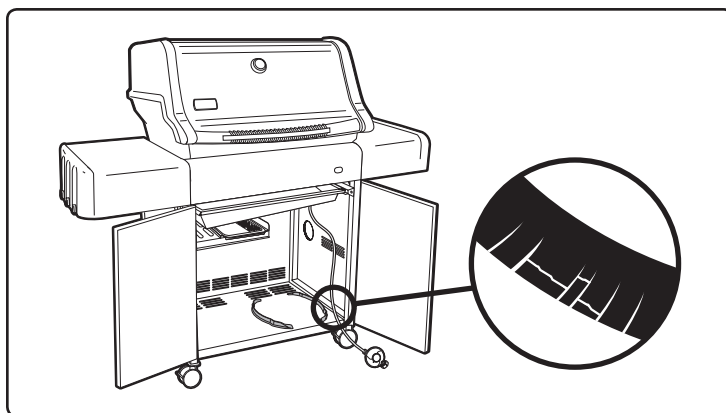

MAIN BURNER IGNITION & USAGE

MAIN BURNER IGNITION

Summary lighting instructions are inside the left-hand cabinet door.

⚠ DANGER

Failure to open the lid while igniting the barbecue's burners, or not waiting five minutes to allow the gas to clear if the barbecue does not light, may result in an explosive flame-up, which can cause serious bodily injury or death.

Crossover® Ignition System

Note - The Crossover® ignition system ignites BURNER 1 with a spark from the igniter electrode inside the Gas Catcher™ ignition chamber. You generate the energy for the spark by pushing the electronic ignition button. You will hear it clicking.

⚠ **WARNING:** Check hose each time before using barbecue for nicks, cracking, abrasions or cuts. If the hose is found to be damaged in any way, do not use the barbecue. Replace using only Weber® authorised replacement hose. Contact the Customer Service Representative in your area using the contact information on our web site. Log onto www.weber.com®.

- A) Open the lid (1).
- B) Make sure all burner control knobs are turned off (2). (Push control knob down and turn clockwise to ensure that it is in the OFF position.)
- ⚠ **WARNING:** The burner control knobs must be in the OFF position before turning on the LP cylinder valve.
- C) Turn on the cylinder valve using one of the appropriate options based on your cylinder and regulator type (3).
- ⚠ **WARNING:** Do not lean over the open barbecue. Keep your face and body at least one foot away from the matchlight hole when lighting the barbecue.
- D) Push BURNER 1 control knob down and turn to START/Hi (4).
- E) Push and hold the electronic ignition button. You will hear it clicking (5).
- F) Check that the burner is lit by looking through the matchlight hole on the front of the cookbox (6). You should see a flame.
- ⚠ **WARNING:** If the burner does not light, turn the Burner 1 control knob to OFF and wait five minutes to let the gas clear before you try again or try to light with a match.
- G) After BURNER 1 is lit you can turn on BURNER 2 and BURNER 3 (7).

Note - Always light BURNER 1 first. The other burners ignite from BURNER 1. ♦

TO EXTINGUISH

Push down and turn each burner control knob clockwise to the OFF position. Turn gas supply OFF at the source. ♦

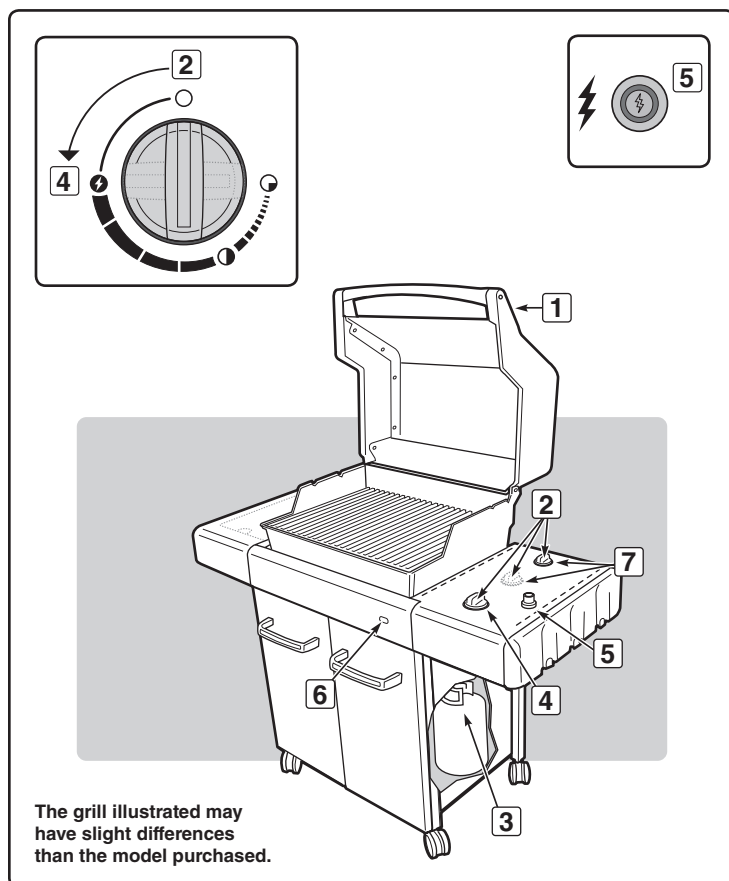

MAIN BURNER IGNITION & USAGE

MAIN BURNER MANUAL IGNITION

⚠ DANGER

Failure to open the lid while igniting the barbecue's burners, or not waiting five minutes to allow the gas to clear if the barbecue does not light, may result in an explosive flare-up, which can cause serious bodily injury or death.

- A) Open the lid (1).
- B) Make sure all burner control knobs are turned off (2). (Push each knob down and turn clockwise to ensure they are in the OFF position.)
- ⚠ **WARNING: The burner control knobs must be in the OFF position before turning on the LP cylinder valve.**
- C) Turn on the cylinder valve using one of the appropriate options based on your cylinder and regulator type (3).
- D) Insert match holder with lit match into the matchlight hole in the front of the cookbox (4).
- ⚠ **WARNING: Do not lean over open barbecue. Keep your face and body at least one foot away from the matchlight hole when lighting the barbecue.**
- E) Push BURNER 1 control knob down and turn to START/Hi (5).
- F) Check that the burner is lit by looking through the matchlight hole on the front of the cookbox (6). You should see a flame.
- ⚠ **WARNING: If the burner does not light, turn the Burner 1 control knob to OFF and wait five minutes to let the gas clear before you try again or try to light with a match.**
- G) After BURNER 1 is lit, you can turn on BURNER 2 and BURNER 3 (7).

Note - Always light BURNER 1 first. The other burners ignite from BURNER 1. ♦

TO EXTINGUISH

Push down and turn each burner control knob clockwise to the OFF position. Turn gas supply OFF at the source. ♦

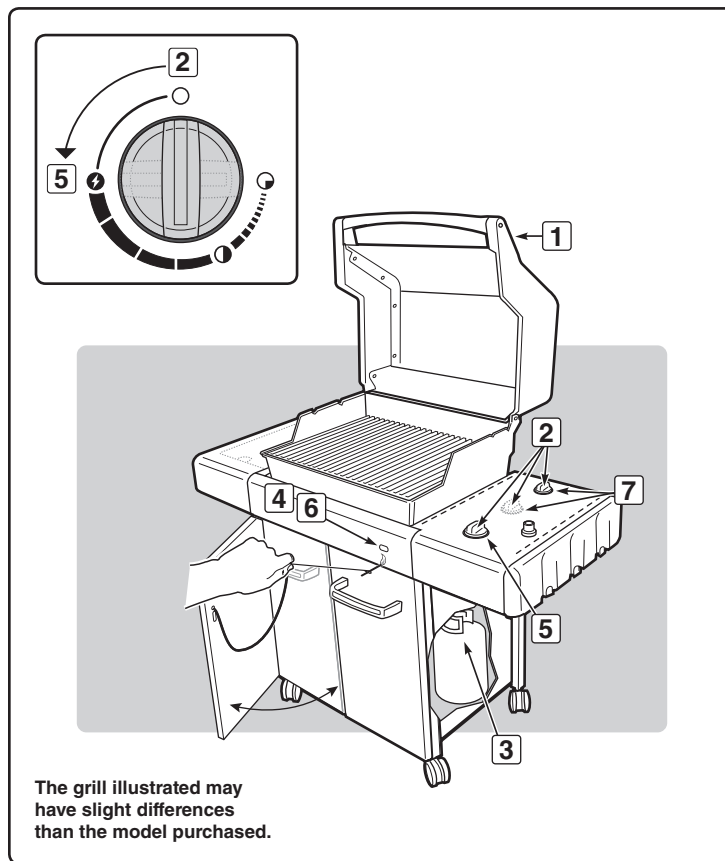

GRILLING TIPS & HELPFUL HINTS

- Always preheat the grill before cooking. Set all burners on HI heat and close lid; heat for 10 minutes, or until thermometer registers 500°-550°F (260°-288°C).
- Sear meats and cook with the lid down for perfectly grilled food every time.
- Grilling times in recipes are based on 70°F (20°C) weather and little or no wind. Allow more cooking time on cold or windy days, or at higher altitudes. Allow less cooking time in extremely hot weather.
- Grilling times can vary because of the weather, or the amount, size and shape of the food being grilled.
- The temperature of your gas grill may run hotter than normal for the first few uses.
- Grilling conditions may require the adjustment of the burner controls to attain the correct cooking temperatures.
- In general, large cuts of meat will require more cooking time per pound than small cuts of meat. Foods on a crowded cooking grate will require more cooking time than just a few foods. Foods grilled in containers, such as baked beans, will require more time if grilled in a deep casserole rather than a shallow baking pan.
- Trim excess fat from steaks, chops and roasts, leaving no more than a scant ¼ inch (6.4mm) of fat. Less fat makes cleanup easier, and is a virtual guarantee against unwanted flare-ups.
- Foods placed on the cooking grate directly above burners may require turning or moving to a less hot area.
- Use tongs rather than a fork for turning and handling meats to avoid losing natural juices. Use two spatulas for handling large whole fish.
- If an unwanted flare-up should occur, turn all burners off and move food to another area of the cooking grate. Any flames will quickly subside. After flames subside, relight the grill. NEVER USE WATER TO EXTINGUISH FLAMES ON A GAS GRILL.
- Some foods, such as a casserole or thin fish fillets, will require a container for grilling. Disposable foil pans are very convenient, but any metal pan with ovenproof handles can also be used.
- Always be sure the grease tray and catch pan are clean and free from debris.
- Do not line the slide-out grease tray with foil. This could prevent the grease from flowing into the catch pan.
- Using a timer will help to alert you when “well-done” is about to become “over-done.”

Note: If grill loses heat while cooking refer to the troubleshooting section of this manual.

⚠ WARNING: Do not move the Weber® gas barbecue when operating or while barbecue is hot.

You can adjust the individual burners as desired. The control settings are OFF, START/HI, MEDIUM, or LOW.

Note: The temperature inside your cookbox for the first few uses, while surfaces are still very reflective, may be hotter than those shown in your cookbook. Cooking conditions, such as wind and weather, may require the adjustment of the burner controls to obtain the correct cooking temperatures.

If burners go out during cooking, open lid, turn off all burners and wait five minutes before relighting.

⚠ WARNING: Check the slide-out grease tray and catch pan for grease build-up before each use. Remove excess grease to avoid a grease fire in the slide-out grease tray. ♦

PREHEATING

Your Weber® gas barbecue is an energy-efficient appliance. It operates at an economical low BTU rate. Preheating the grill before grilling is important. Light your grill according to the instructions in this Owner's Manual. To preheat: after lighting turn all burners to START/HI, close the lid, and heat until the temperature reaches between 500°F and 550°F (260° and 288° C), the recommended broiling temperature. This will take 10 to 15 minutes depending on conditions such as air temperature and wind. ♦

COVERED COOKING

All grilling is done with the lid down to provide uniform, evenly circulated heat. With the lid closed, the gas grill cooks much like a convection oven. The thermometer in the lid indicates the cooking temperature inside the grill. All preheating and grilling is done with the lid down. No peeking — heat is lost every time you lift the lid. ♦

DRIPPINGS AND GREASE

The Flavorizer® bars are designed to “smoke” the correct amount of drippings for flavoursome cooking. Excess drippings and grease will accumulate in the catch pan under the slide-out grease tray. Disposable foil drip pans are available that fit the catch pan. ♦

FLAVORIZER® SYSTEM

When meat juices drip from the food onto the specially angled Flavorizer® bars, they create smoke that gives foods an irresistible barbecued flavour. Thanks to the unique design of the burners, Flavorizer® bars and the flexible temperature controls, uncontrolled flare-ups are virtually eliminated, because YOU control the flames. Because of the special design of the Flavorizer® bars and burners, excess fats are directed through the slide-out grease tray into the grease catch pan. ♦

TROUBLESHOOTING

PROBLEM	CHECK	SOLUTION
Burners burn with a yellow or orange flame, in conjunction with the smell of gas.	Inspect Spider/Insect screens for possible obstructions. (Blockage of holes.)	Clean Spider/Insect screens. Refer to "ANNUAL MAINTENANCE".
Symptoms: Burners do not ignite. -or- Burners have a small flickering flame in the HI position. -or- Barbecue temperature only reaches 250° to 300° in the HI position. <i>Some countries have regulators with an excess gas flow safety device.</i>	The excess flow safety device, which is part of the barbecue-to-cylinder connection, may have activated.	To reset the excess flow safety device turn all burner control knobs and the cylinder valve off. Disconnect the regulator from the cylinder. Turn burner control knobs to HI. Wait at least 1 minute. Turn burner control knobs to OFF. Reconnect the regulator to the cylinder. Turn cylinder valve on slowly. Refer to "MAIN BURNER IGNITION".
Burner does not light, or flame is low in HI position.	Is LP fuel low or empty?	Refill LP cylinder.
	Is fuel hose bent or kinked?	Straighten fuel hose.
	Does burner light with a match?	If burner lights with a match then some of the burner port openings may be clogged. Clean burners. Refer to "MAINTENANCE".
Burner does not ignite when you push the igniter button.	Be sure that there is gas flow to the burners by attempting to match light your burners. Refer to "MAIN BURNER MANUAL IGNITION".	If match lighting is successful, the problem lies in the ignition system. Refer to "ELECTRONIC IGNITION SYSTEMS OPERATIONS".
	Is there a fresh battery installed?	Verify that the battery is in good condition and installed correctly. Refer to "ELECTRONIC IGNITER INSPECTION".
	Are the wires connected properly to the igniter module?	Be sure that wires are correctly inserted into terminals on ignition box. Refer to "ELECTRONIC IGNITION SYSTEMS OPERATIONS".
	Is there plastic wrapping around the new battery?	Remove plastic wrapping.
Experiencing flare-ups: ⚠ CAUTION: Do not line the slide-out grease tray with aluminum foil.	Are you preheating barbecue in the prescribed manner?	All burners on HI for 10 to 15 minutes for preheating.
	Are the cooking grates, heat deflectors, and Flavorizer® bars heavily coated with burned-on grease?	Clean thoroughly. Refer to "CLEANING".
	Is the slide-out grease tray dirty and not allowing grease to flow into catch pan?	Clean slide-out grease tray.
Burner flame pattern is erratic. Flame is low when burner is on HI. Flames do not run the whole length of the burner tube.	Are burners clean?	Clean burners. Refer to "MAINTENANCE".
Inside of lid appears to be "peeling." (Resembles paint peeling.)	The inside of the lid is porcelain enamel or stainless steel, and is not painted. It cannot "peel." What you are seeing is baked on grease that has turned to carbon and is flaking off. THIS IS NOT A DEFECT.	Clean thoroughly. Refer to "CLEANING".
Cabinet doors are not aligned.	Check the adjustment pin on the bottom of each door.	Loosen adjustment nut(s). Slide door(s) until aligned. Tighten nut.
If problems cannot be corrected by using these methods, please contact the Customer Service Representative in your area using the contact information on our web site. Log onto www.weber.com ®.		

MAINTENANCE

CLEANING

⚠ **WARNING:** Turn your Weber® gas barbecue off and wait for it to cool before cleaning.

⚠ **CAUTION:** Do not clean your Flavorizer® bars or cooking grates in a self-cleaning oven.

Outside surfaces - Use a warm soapy water solution to clean, then rinse with water.

⚠ **CAUTION:** Do not use oven cleaner, abrasive cleansers (kitchen cleansers), cleaners that contain citrus products, or abrasive cleaning pads on barbecue or cart surfaces.

Slide-out grease tray - Remove excess grease, then wash with warm soapy water, then rinse.

⚠ **CAUTION:** Do not line the slide-out grease tray with aluminum foil.

Flavorizer® bars and cooking grates - Clean with a suitable stainless steel bristle brush. As needed, remove from grill and wash with warm soapy water, then rinse with water.

For availability of replacement cooking grates and Flavorizer® bars, contact the Customer Service Representative in your area using the contact information on our website. Log onto www.weber.com.

Catch pan - Disposable foil trays are available, or you can line the catch pan with aluminum foil. To clean the catch pan, wash with warm soapy water, then rinse.

Thermometer - Wipe with warm soapy water; clean with plastic scrub ball.

Cookbox - Brush any debris off burner tubes. DO NOT ENLARGE BURNER PORTS (OPENINGS). Wash inside of cookbox with warm soapy water and rinse with water.

Inside lid - While lid is warm, wipe inside with paper towel to prevent grease build-up. Flaking, built-up grease resembles paint flakes.

Stainless steel surfaces - Wash with a soft cloth and a soap-and-water solution. Be careful to scrub with the grain direction of the stainless steel.

Do not use cleaners that contain acid, mineral spirits or xylene. Rinse well after cleaning. ♦

PRESERVE YOUR STAINLESS STEEL

Your grill or its cabinet, lid, control panel and shelves may be made from stainless steel. To keep the stainless steel looking its best is a simple matter. Clean it with soap and water, rinse with clear water and wipe dry. For stubborn particles, the use of a non-metallic brush can be used.

⚠ **IMPORTANT:** Do not use a wire brush or abrasive cleaners on the stainless steel surfaces of your grill as this will cause scratches.

⚠ **IMPORTANT:** When cleaning surfaces be sure to rub/wipe in the direction of the grain to preserve the look of your stainless steel. ♦

WEBER® SPIDER/INSECT SCREENS

Your Weber® gas barbecue, as well as any outdoor gas appliance, is a target for spiders and other insects. They can nest in the venturi section (1) of the burner tubes. This blocks the normal gas flow, and can cause the gas to flow back out of the combustion air opening. This could result in a fire in and around the combustion air openings, under the control panel, causing serious damage to your barbecue.

The burner tube combustion air opening is fitted with a stainless steel screen (2) to prevent spiders and other insects from accessing the burner tubes through the combustion air openings.

We recommend that you inspect the Spider/Insect screens at least once a year. (Refer to "ANNUAL MAINTENANCE"). Also inspect and clean the Spider/Insect screens if any of the following symptoms should ever occur:

- A) The smell of gas in conjunction with the burner flames appearing yellow and lazy.
- B) Barbecue does not reach temperature.
- C) Barbecue heats unevenly.
- D) One or more of the burners do not ignite.

⚠ DANGER

Failure to correct the above mentioned symptoms may result in a fire, which can cause serious bodily injury or death, and cause damage to property. ♦

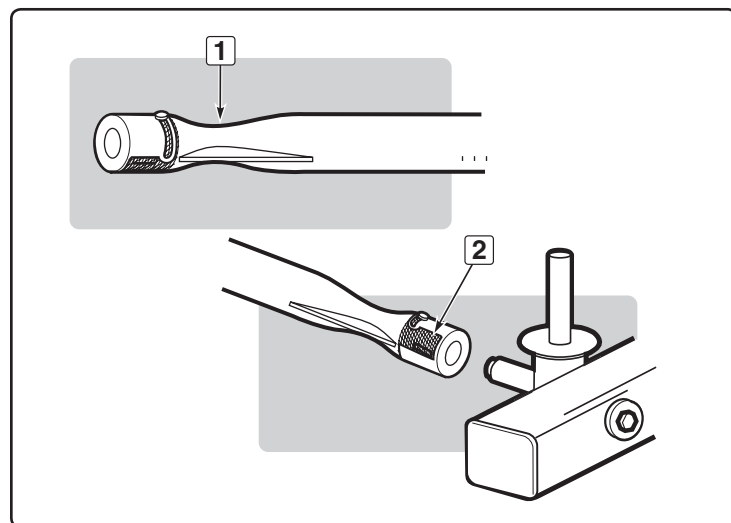

BURNER TUBES CLEANING OR REPLACEMENT

You will need: Phillips screwdriver and flathead screwdriver.

- A) Your Weber® gas barbecue must be OFF and cool.
- B) Turn gas OFF at source.
- C) Remove cookbox components - warming rack, grates and Flavorizer® bars.

Control Panel Removal

- D) To remove control panel:
 - a) Take off the burner control knobs (1).
 - b) Remove screw and washer from back of control panel with a Phillips screwdriver (2).
 - c) Remove machine screw from lower left and right side of control panel with a Phillips screwdriver (3).
 - d) Tilt the back edge of the control panel up. Carefully lift control panel up and away from frame (4).
 - e) Disconnect the igniter wires from the ignition module (5).

Burner Tube Removal

- E) To remove burner tube(s):
 - a) Remove the two nuts (6) that hold the manifold support bracket to the cookbox. Pull the manifold and valve assembly towards you, at the same time lift the manifold assembly up to release the manifold brackets from the frame assembly (7).
 - b) Slide the burner assembly out from under the guide screw and washer (8) in the corners of the cookbox.
 - c) Lift and twist the burner assembly slightly, to separate the Crossover® tube (9) from the burners. Remove the burners from the cookbox.

Burner Tube Cleaning

- F) To clean the burner tube(s):
 - a) Look inside each burner with a flashlight (10).
 - b) Clean the inside of the burners with a wire (11) (a straightened-out coat hanger will work).
 - c) Check and clean the air shutter opening at the ends of the burners. Check and clean the valve orifices at the base of the valves. Use a steel bristle brush to clean outside of burners (12). This is to make sure all the burner ports are fully open.

⚠ **CAUTION:** Do not enlarge the burner ports when cleaning.

Burner Tube Reinstallation

- G) To reinstall burner tubes:
 - a) Reverse steps D) through E).

⚠ **CAUTION:** The burner openings (13) must be positioned properly over the valve orifices (14).

Check proper assembly before fastening manifold in place.

⚠ **WARNING:** After reinstalling the gas lines, they should be leak-checked with a soap-and-water solution before using the barbecue. (Refer to "CHECK FOR GAS LEAKS")

⚠ **WARNING:** Make sure that all parts are assembled and hardware is fully tightened before operating the grill. Your actions, if you fail to follow this Product Warning, may cause a fire, an explosion, or structural failure resulting in serious personal injury or death as well as damage to property. ♦

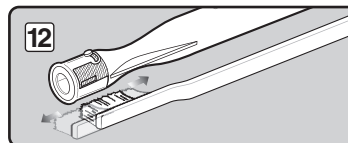
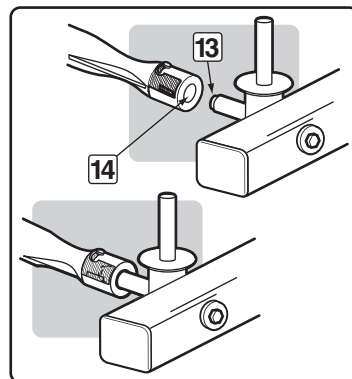
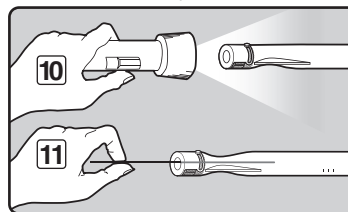
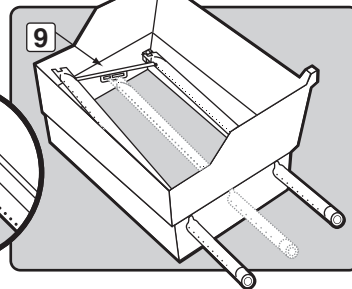
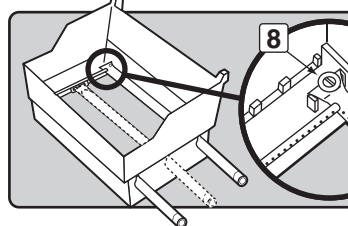
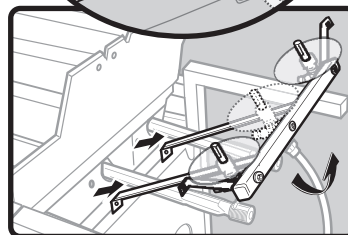
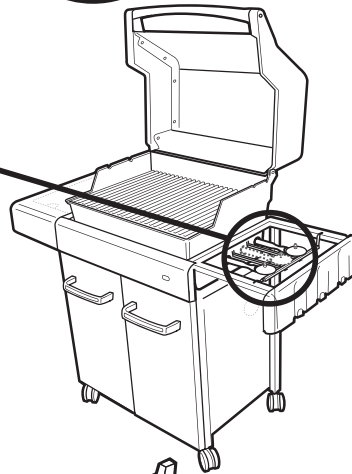
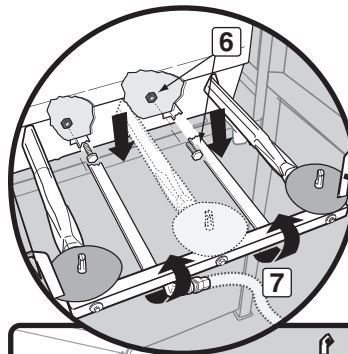
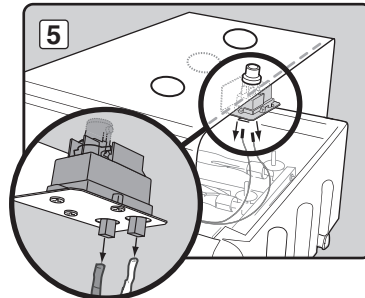
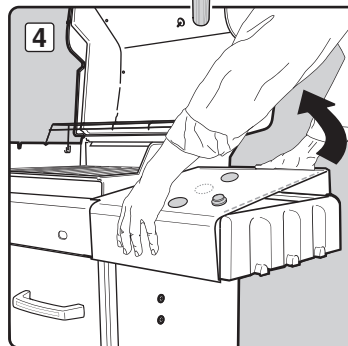
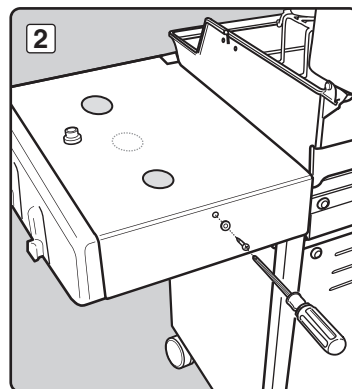
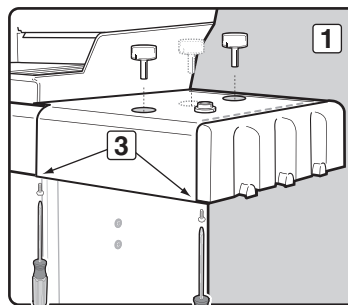

MAINTENANCE

ELECTRONIC CROSSOVER® IGNITION SYSTEM OPERATIONS

If the Electronic Crossover® Ignition System fails to ignite the BURNER 1, light BURNER 1 with a match. If BURNER 1 lights with a match, then check the Electronic Ignition.

- Check that both of the ignition wires are attached at the igniter module properly.
- Check that the Electronic Ignition button is working by listening and looking for sparks at BURNER 1.

Replace Battery If Necessary

AAA alkaline battery only.

If the Electronic Crossover® Ignition System still fails to light, contact the Customer Service Representative in your area using the contact information on our web site. Log onto www.weber.com®. ♦

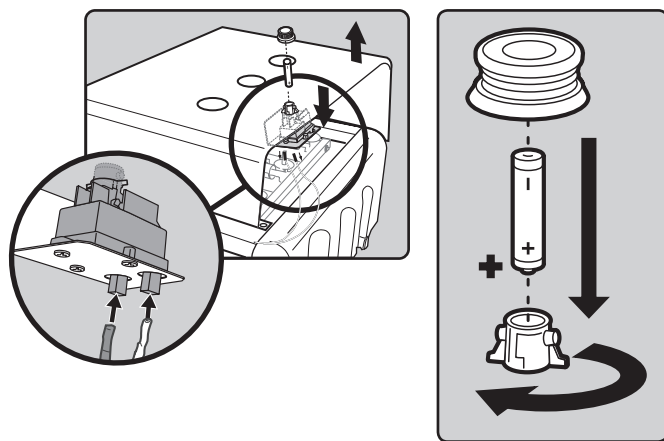

ANNUAL MAINTENANCE

Inspection And Cleaning Of The Spider/Insect Screens

To inspect the Spider/Insect screens, remove the control panel. If there is dust or dirt on the screens, remove the burners to clean the screens.

Brush the Spider/Insect screens lightly with a soft bristle brush (i.e. an old toothbrush).

⚠ CAUTION: Do not clean the Spider/Insect screens with hard or sharp tools. Do not dislodge the Spider/Insect screens or enlarge the screen openings.

Lightly tap the burner to get debris and dirt out of the burner tube. Once the Spider/Insect screens and burners are clean, replace the burners.

If the Spider/Insect screen becomes damaged or cannot be cleaned, please contact the Customer Service Representative in your area using the contact information on our web site. Log onto www.weber.com®.

Burner Flame Pattern

The Weber® gas barbecue burners have been factory-set for the correct air and gas mixture. The correct flame pattern is shown.

- A) Burner tube (1)
- B) Tips occasionally flicker yellow (2)
- C) Light blue (3)
- D) Dark blue (4)

If the flames do not appear to be uniform throughout the burner tube, follow the burner cleaning procedures. ♦

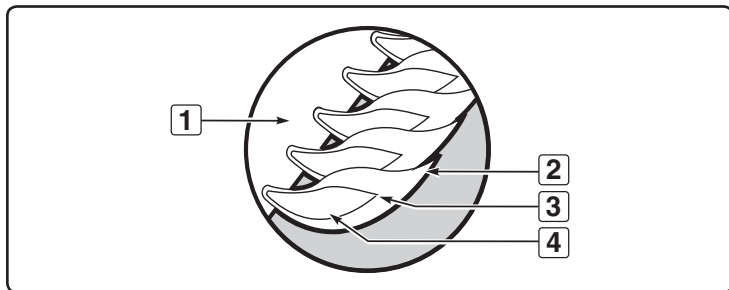
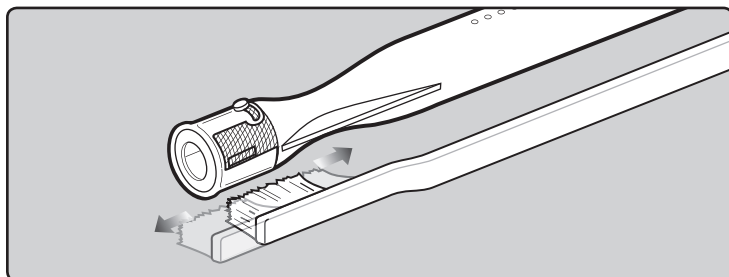

⚠ ATTENTION: This product has been safety-tested and is only certified for use in a specific country. Refer to country designation located on outside of box.

These parts may be gas-carrying or gas-burning components. Please contact Weber-Stephen Products LLC Customer Service Department for genuine Weber-Stephen Products LLC replacement part(s) information.

⚠ WARNING: Do not attempt to make any repair to gas-carrying or gas-burning components without contacting Weber-Stephen Products LLC Customer Service Department. Your actions, if you fail to follow this product warning, may cause a fire or an explosion resulting in serious personal injury or death and damage to property.



This symbol indicates that the product cannot be disposed of with household refuse. For instructions regarding proper disposal of this product in Europe, please visit www.weber.com, and contact the importer listed for your country. If you do not have internet access, contact your dealer for the importer's name, address and telephone number.

When you decide to dispose of or discard your barbecue, all electrical components (e.g. rotisserie motor, batteries, ignition module, handle lights) must be removed and disposed of properly according to WEEE. They should be disposed of separately from the barbecue.

WEBER-STEPHEN ÖSTERREICH GMBH

Maria-Theresia-Straße 51
4600 Wels
AUSTRIA
PH: +43.7242.890 135.0
Main Fax: +43.7242.890 135.45
info-at@weberstephen.com

WEBER-STEPHEN PRODUCTS

Chaussee de Waterloo 200 Bte 3
Waterloosesteenweg 200 Bus 3
1640 St. Genesius Rode
BELGIUM
PH: 32.2.359.98.10

GRAHAM SA/NV

Parc Industriel 21
1440 Wauthier-Braine
BELGIUM
PH: 32.2.367.1611

WEBER-STEPHEN CZ & SK spol. s r.o.

U Hajovny 246
25243 Průhonice
CZECH REPUBLIC
PH: +42.267312.973
Main Fax: +42.267.750.897
info-cz@weberstephen.com

WEBER-STEPHEN NORDIC

Boegildsmindevej 23B
9400 Noerresundby
Denmark
PH: 45.99.36.30.10

WEBER-STEPHEN NORDIC MIDDLE EAST

Ras Al Khaimah FTZ
P.O. Box 10559, UAE
PH: +971 4 360 9256
Fax: +971 4 421 5263
ASJensen@weberstephen.ae

WEBER-STEPHEN FRANCE SARL

Parc d'activité des Bellevues
Le Hyde Park Immeuble "Le Piccadilly"
16 Allée Rosa Luxembourg
95610 Ergany sur Oise
FRANCE
PH: 33.1.39.09.9000

WEBER-STEPHEN DEUTSCHLAND GMBH

Rheinstraße 194
55128 Ingelheim
GERMANY
PH: +49.6132.8999.0
Main Fax: +49.6132.8999.69
info-de@weberstephen.com

WEBER-STEPHEN HOLLAND B.V.

Tsjükemarwei 12
8521 NA Sint Nicolaasga
Postbus 18
8520 AA Sint Nicolaasga
HOLLAND
PH: +31.513.4333.22
Main Fax: +31.513.4333.23
info@weberbarbecues.nl

JARN & GLER WHOLESAL EHF

Skutuvogur 1H
1-104 Reykjavik
ICELAND
PH: 354.58.58.900

D&S IMPORTS

14 Shenkar Street
Petach, Tikva 49001
ISRAEL
PH: 972.392.41119

MAGI & CO P.S.C.L. SIGNORI DEL BARBECUE

Via Masetti 14
40033 Casalecchio di Reno
Bologna
ITALY
PH: 39.051.613.3257

WEBER-STEPHEN POLSKA Sp. z o.o.

Ul. Minerska 29 lok.1
04-506 Warszawa
POLSKA
PH: +48.22.392.04.69
Main Fax: +48.22.397.70.52
info-pl@weberstephen.com

GALACTEX OURDOOR (PTY) LTD.

141-142 Hertz Draai
Meadowdale, Edenvale
Gauteng, SOUTH AFRICA
PH: 27.11.454.2369

WEBER-STEPHEN IBERICA, S.R.L.

Av. Alcalde Barnils 64-68
Edificio A, 3º2º, 08190
Sant Cugat del Vallés
Barcelona
SPAIN
PH: 00.34.935.844.055

WEBER-STEPHEN SCHWEIZ GMBH

Talackerstr. 89a
8404 Winterthur
Switzerland
PH: +41.52.24402.50
Main Fax: +41.52.24402.59
info-ch@weberstephen.com

**WEBER-STEPHEN PRODUCTS –
NORTHERN EUROPE REGION**

The Four Columns
Broughton Hall Business Park
Skipton
North Yorkshire
BD23 3AE
United Kingdom
PH: 44.1756.692600

WEBER-STEPHEN PRODUCTS LLC

200 East Daniels Road
Palatine, IL 60067-6266
USA
PH: 847.934.5700

WEBER – STEPHEN Vostok LTD®

119270, office 105,
2/4 building 3, Luzhnetskaya
naberezhnaya Moscow
PH: +7 495 973 16 49
Main Fax: +7 95 336 31 11
info-ru@weberstephen.com

WEBER-STEPHEN MAGYARORSZÁG KFT.

1037 Budapest, Montevideó u. 2/B.
HUNGARY
PH: +36 70 / 70-89-813

RÖSLER SLOVENIJA - MATIC STROPNIK

Rajšpova ul.22, 2250 Ptuj, SLO
SLOVENIA/CROATIA
PH: +386 2 749 38 62

For Republic of Ireland please contact:
Weber-Stephen Products - Northern Europe Region

For other Eastern Europe countries,
TURKEY, GREECE please contact:
Weber-Stephen Deutschland GmbH.,
info-de@weberstephen.com

For Baltic States please contact:
Weber-Stephen Nordic.



WEBER-STEPHEN PRODUCTS LLC

www.weber.com®