



SMOKEY MOUNTAIN COOKER™ SMOKER

19 inch
(49 cm)



63230

OWNER'S GUIDE AND COOKBOOK

**DO NOT DISCARD. THIS CONTAINS IMPORTANT
PRODUCT DANGERS, WARNINGS AND CAUTIONS.**

***Note - Do not operate this smoker until
you have read this owner's guide.***

| | |
|---------------------------------|-------|
| Warnings | 4 |
| Assembly Instructions | 6-9 |
| Helpful Hints | 10 |
| Cleaning | 11 |
| Getting Started | 12 |
| Brine Cure | 13 |
| Cooking Charts | 14-15 |
| Recipes | 16-23 |
| Barbecuing | 24-26 |
| Steaming | 27 |

⚠ DANGER

Failure to follow the Dangers, Warnings and Cautions contained in this Owner's Manual may result in serious bodily injury, death, or fire causing damage to property.

⚠ WARNINGS

- ⚠ This smoker is designed for outdoor use only. If used indoors, toxic fumes will accumulate and cause serious bodily injury or death.**
- ⚠ Do not add charcoal lighter fluid or charcoal impregnated with charcoal lighter fluid to hot or warm coals. Cap starter fluid after use, and place a safe distance away from the barbecue.**
- ⚠ Do not use gasoline, alcohol, or other highly volatile fluids to ignite charcoal. If using charcoal lighter fluid, remove any fluid that may have drained through the bottom vents, before lighting the charcoal.**
- ⚠ Do not leave infants, children, or pets unattended near a hot smoker.**
- ⚠ Do not attempt to move a hot smoker.**
- ⚠ Do not use this smoker within five feet of any combustible material.**
- ⚠ Do not use this smoker unless all parts are in place.**
- ⚠ Do not remove ashes until all coals are completely burned out and are fully extinguished.**
- ⚠ Do not wear clothing with loose flowing sleeves while lighting or using the smoker.**
- ⚠ Do not use smoker in high winds.**
- ⚠ Keep the smoker in a level position at all times.**

- ⚠ Combustion by-products produced when using this product contain chemicals known to the state of California to cause cancer, birth defects, or other reproductive harm.**
- ⚠ Remove the lid from the smoker while lighting and getting the coals started.**
- ⚠ Always put charcoal on top of the charcoal grate and not directly into the bottom of the bowl.**
- ⚠ Never touch the cooking or charcoal grate, or the smoker, to see if they are hot.**
- ⚠ Barbecue mitts or hot pads should always be used to protect hands while barbecuing or adjusting the vents.**
- ⚠ Use proper barbecue tools with long, heat-resistant handles.**
- ⚠ To extinguish the coals, place the lid on the bowl and close all vents. Do not use water, it will damage the porcelain finish.**
- ⚠ To control flare-ups, place lid on smoker. Do not use water.**
- ⚠ Handle and store hot electric starters carefully.**
- ⚠ Keep electrical cords away from the hot surfaces of the smoker. Lining the bowl with aluminum foil will obstruct the air flow, instead use a drip pan to catch drippings from meat when cooking by the Indirect Method.**
- ⚠ Using sharp objects to clean the cooking grate or remove ashes will damage the finish.**
- ⚠ Using abrasive cleaners on the cooking grate or the smoker itself will damage the finish.**

6

1

Check Package Contents

You should have received the parts listed at right. While we give much attention to our product, an occasional error may occur. If a part is missing, do not go back to the store. Call the Weber-Stephen Products Customer Service Center toll-free at **1-800-446-1071** to receive immediate assistance.

Lid
Three legs
Center ring
Charcoal chamber
Bowl
Water pan
Door assembly
Four grill straps
No-handled cooking grate

Charcoal grate
Handled cooking grate

Hardware Pack Contents:

14 - $\frac{1}{4}$ -20 x $\frac{5}{8}$ " screws
14 - $\frac{1}{4}$ -20 nuts
8 - Fiber washers
6 - $\frac{1}{4}$ " steel washers

2

Assemble Legs

You will need: bowl, three legs, six screws, six steel washers, six nuts, an adjustable wrench and a screwdriver.

Set bowl on the ground. Place leg against bowl and insert one screw into each end of leg. Slip a steel washer over each screw, add a nut and hand tighten.

Repeat this for the other two legs.

With the three legs in position, tighten assembly using an adjustable wrench and screwdriver.

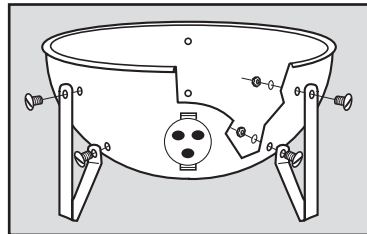

3

Assemble Charcoal Grate and Charcoal Chamber

You will need: charcoal grate and charcoal chamber.

Set charcoal grate into bowl. Set charcoal chamber on charcoal grate.

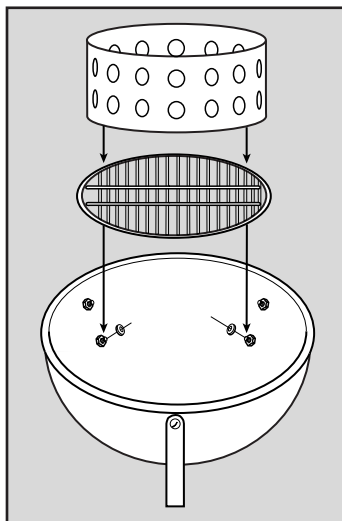

4

Attach Grill Straps to Center Ring

You will need: four grill straps, eight fiber washers, eight screws, eight nuts, center ring, an adjustable wrench and screwdriver.

Place a fiber washer on each of the screws and insert into each hole in center ring, with heads of screws on the outside. Place grill straps inside the ring over the screws, making sure the two "ledges" are at the bottom. Place a nut on each of the screws and tighten securely with an adjustable wrench and screwdriver.

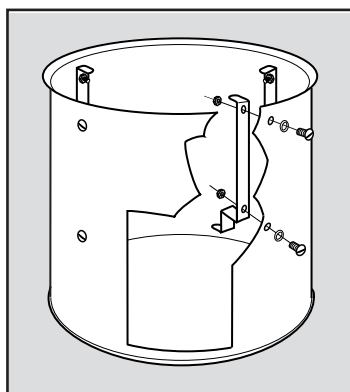

5

Install Center Ring and Bowl

You will need: center ring assembly from Step 4 and bowl assembly from Step 3. Place center ring assembly onto bowl.

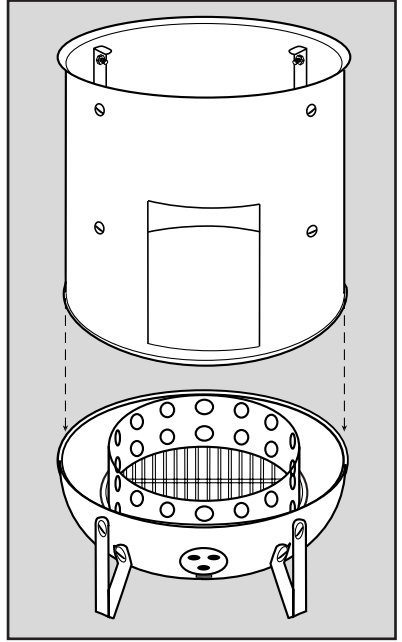

6

Install Door Assembly

You will need: door assembly and center ring to bowl assembly.

Holding door assembly on a slight angle, place door assembly into opening in center ring. To open or close, turn knob.

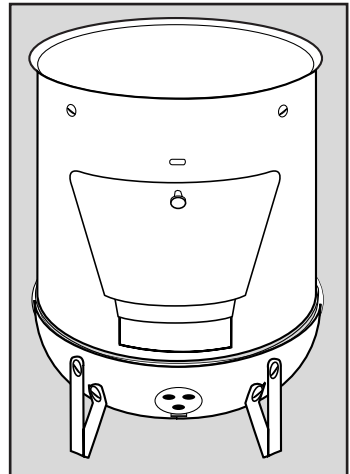

7

Complete Assembly

You will need: lid, water pan, no-handled cooking grate and handled cooking grate. Place water pan on the bottom ledge of grill strap. Place no-handled cooking grate on middle ledge of strap. Place handled cooking grate on very top ledge of strap. Set lid on top.

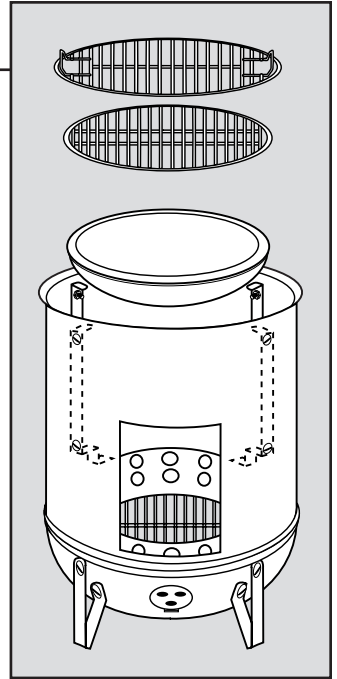

8

Steaming and Barbecuing

To steam: arrange the charcoal grate, charcoal chamber, and water pan on the middle ledge grill strap. Place no-handled cooking grate on top of the water pan. Place handled cooking grate aside.

To barbecue: arrange the charcoal grate and charcoal chamber on the middle ledge grill strap. Set aside no-handled cooking grate and water pan. Place handled cooking grate on very top ledge of strap.

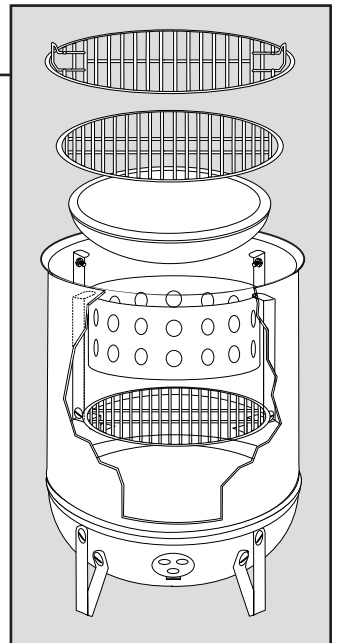

Helpful Hints

Please read all instructions before using your smoker.

- Always cook with the cover on your smoker.
- Use tongs for turning meats to avoid piercing meat and losing natural juices.
- Resist the temptation to look at the foods during cooking time—every time the lid is lifted it will be necessary to add 15 minutes to the cooking time.
- Use a meat thermometer to determine the internal temperature of meat—it should be inserted into the thickest part of the meat and should not touch fat or bone.
- Charcoal should be stored in a dry place—damp charcoal will not burn well.
- Always use barbecue mitts or hot pads to protect your hands.
- Adjust vents as indicated for each method of cooking in your smoker:

Smoking—all vents partially closed.

Barbecuing—all vents wide open.

Steaming—top vent closed, bottom vents open.

- All vents should be wide open when preparing the fire.
- Close all vents to extinguish the coals when you are finished cooking. Do not use water to extinguish coals as it may damage the porcelain finish.
- There are many variables that influence smoking, fortunately most of them can be controlled by the person doing the cooking. However, there are some things that we cannot control, such as weather, wind and altitude. So, to be on the safe side, add extra time to your cooking schedule when necessary, usually half to 1 hour is adequate.
- Smoker should be placed on a level heat proof surface away from buildings and out of the general traffic path. The smoker is for outdoor use only and not recommended for use on carpeted surfaces. Since the aroma of smoke can linger it is best to find a place away from the house to do your smoke-cooking.
- Experiment with different varieties of wood and amounts used. You can also add bay leaves, garlic cloves, mint leaves, orange or lemon peel and various spices to the charcoal for added flavor. Keep a record of your experiments—it's easy to forget what you did last time.

Note: Do not use charcoal that has been impregnated with a starter fluid in your smoker. This is especially important when adding charcoal during the cooking time, because it can give an unpleasant taste to your food.

Cleaning

It isn't necessary to clean the inside walls of your smoker, however, if you wish, they may be wiped down occasionally. The outside of the unit may be cleaned with a sudsy cloth and rinsed with a damp cloth.

If you use aluminum foil to completely cover the water pan it will aid the clean-up chore. Grease tends to build up on the inside and outside of the water pan. When the grease build-up is baked onto the pan it may flake off—this is not porcelain flaking off—it is hardened, baked-on grease and can be cleaned off with a spray-on oven cleaner. Follow the manufacturers directions on oven cleaner.

Frequently remove ashes from the bottom section of the smoker.

Getting Started

- Remove top and center ring before starting the fire. Open all vents.
- Fill charcoal chamber with the amount of charcoal recommended on chart for food being cooked. Heap charcoal in center of grill. Ignite the charcoal.
- When the coals have a light coating of gray ash (about 30 minutes) spread them evenly across the inside of the charcoal chamber.
- Place the water pan in position on the lower bracket of the center ring. Fill pan with hot tap water.
- Put the lower cooking grill in place on bracket above water pan. The 18½" cooking grill should be positioned on the top bracket.
- Carefully set the center ring in place on top of the bottom section of the smoker.
- Arrange food in a single layer on the cooking grills leaving space between each piece of food. (Both grills may be used for food.)
- Open door on front of smoker to place wet wood chunks on top of the hot coals.
- Partially close all vents while smoke-cooking. Use barbecue mitts to protect your hands while adjusting the vents.
- Place recommended amount of wood chunks in a pan of water to soak at least 1 hour before using.
- Shake excess water off wood chunks before placing them on top of the hot coals.
- Different hardwoods will impart a variety of flavors. Do some experimenting to find the type of hardwood, or combination of hardwoods, that you like best. Start with the lowest amount of wood chunks recommended—more can be added to suit your own taste. Some experimenting will be necessary to find the amount of smoke flavor you prefer. (Use pieces of wood approximately 2" x 3" in size.)
- By keeping records of your smoke-cooking experiences—a beginner can quickly become an expert. Notes you make will be an invaluable aid in your future endeavors. By referring to your notes at a later date you will be able to repeat your successes.
- Smoke-cooked foods look different than oven cooked foods—they may be pink or red when completely cooked. A good meat thermometer is the most accurate way to determine the internal temperature of large cuts of meat.
- Beer, wine, cola, fruit juices, marinades, herbs and spices can be combined with water, in the waterpan, to give additional flavor to your food.
- Meat can be smoke-cooked without curing, or it can be cured before smoking with either a dry cure or in a brine.

Brine Cure

Salting, or curing, reduces the moisture content of meat, retards formation of bacteria and adds flavor as it is absorbed in the meat. When meats require 2 hours or less of curing they may be kept at room temperature, otherwise they should be refrigerated.

Salt is the basic ingredient used in most seasonings and brines for smoking and curing foods. Rock salt, pickling salt or canning salt are less expensive to use than iodized table.

Sugar is also a basic ingredient used in brines and dry cures—it is used during curing to counteract the effects of salt. Sugar can be in the form of white or brown sugar, honey, molasses or syrup—each imparts its own flavor.

Seasoning is more or less a matter of personal taste—spices can be used during or after the curing process to give additional flavor to the meat or fish.

Stone crocks and glass or plastic containers are ideal containers for use in brining or storing leftover brine. (Never use metal containers.)

Meat should be completely submerged in the brine. A weighted plate will be helpful to keep the meat from coming to the surface of the brine.

Contents of the brine solution should be stirred occasionally with a wooden spoon. This is called overhauling. When overhauling a large container of meat it is best to remove the meat from the container, stir the brine, put meat back in container and pour the brine over meat, weighing it down to keep meat completely submerged in the brine.

After a piece of meat or fish is removed from the brine solution it should be given a quick rinse in fresh water and dried before smoking.

Sweet Pickle Brine

1 gal. water
 2½ cups salt
 ½ cup light brown sugar
 1 tablespoon Liquid garlic
 1 oz. pickling spices

Basic Brine

1 quart of water
 ½ cup of salt
 ½ cup light brown sugar
 ½ teaspoon Liquid garlic
 ½ teaspoon pepper

Dry cures can be used instead of a brine solution. They are applied in a dry form directly to the surface of the meat or fish. Meats should be kept at 35° during dry curing. Foods should be rinsed in fresh water and dried before smoking.

Basic Dry Cure

2 cups salt
 ½ cup sugar

Add spices and seasonings of your choice to this mixture. Start with ½ teaspoon of each—experiment to find the combinations you like best with the meat and fish you smoke.

Smoking Cooking Charts

Please note: The amount of wood chunks, water or charcoal is not indicated in each recipe. Please refer to this chart.

- The cooking times listed in the charts are for foods that have been completely thawed.
- Add 12 to 14 briquettes every 1½ hours. When coals are added check the waterpan and add water as necessary to fill pan. Use door on front of unit to add charcoal or water.

| Beef | Weight | Water Pan | Charcoal Layers | Cooking Time | Wood Chunks | Internal Temp |
|-----------------------------|---------------|------------------|------------------------|---------------------|--------------------|----------------------|
| Beef Roast, Beef Brisket | 3-4 lbs. | Full | 2 | 4-5 hrs. | 4-6 | 145° rare |
| Lamb Roast, Venison | 5-7 lbs. | Full | 2 | 5-6 hrs. | 4-6 | 160° med |
| Large cuts of game | 7-9 lbs. | Full | 2 | 6-8 hrs. | 4-6 | 170° well |
| Beef ribs | Full grill | Full | 1 | 3-4 hrs. | 2-4 | 160° well |

| Pork | Weight | Water Pan | Charcoal Layers | Cooking Time | Wood Chunks | Internal Temp |
|---------------------|---------------|------------------|------------------------|---------------------|--------------------|-----------------------|
| Pork Roast | 3-4 lbs. | Full | 2 | 5-6 hrs. | 4-6 | 160° med |
| | 4-8 lbs. | Full | 2 | 6-8 hrs. | 4-6 | 170° well |
| Pork Ribs | Full grill | Full | 1 | 4-6 hrs. | 4-6 | 160° med 170° well |
| Pork Chops | Full grill | Full | 1 | 2-3 hrs. | 2-4 | 160° med 170° well |
| Fresh Ham Whole | 10-18 lbs. | Full | 2 | 8-12 hrs. | 6-8 | 160° med 170° well |
| Whole Ham Cooked | 10-14 lbs. | Full | 1 | 3-4 hrs. | 4-6 | 140° med |

- Always use hot water to fill or replenish the water pan. You might find that a watering can works well.
- If your fire seems to be fizzling out—take the door on the front of the smoker off for a short period of time. The additional oxygen will get the fire going again.

| Poultry | Weight | Water Pan | Charcoal Layers | Cooking Time | Wood Chunks | Internal Temp |
|----------------|----------------|------------------|------------------------|---------------------|--------------------|----------------------|
| Cut up | 1-4 fryers | Full | 1 | 3-4 hrs. | 2-4 | 180° well |
| Whole | 1-4 fryers | Full | 2 | 4-5 hrs. | 2-4 | 180° well |
| Whole | 5 lbs. roaster | Full | 2 | 5-6 hrs. | 2-4 | 180° well |
| Turkey | 8-12 lbs. | Full | 2 | 7-8 hrs. | 6-8 | 180° well |
| Unstuffed | 12-18 lbs. | Full | 2 | 8-10 hrs. | 6-8 | 180° well |
| Duck | 3-5 lbs. | Full | 2 | 4-6 hrs. | 2-4 | 185° well |
| Pheasant | 3-5 lbs. | Full | 2 | 4-6 hrs. | 2-4 | 185° well |
| Goose | 8-10 lbs. | Full | 2 | 7-8 hrs. | 4-6 | 185° well |

| Fish | Weight | Water Pan | Charcoal Layers | Cooking Time | Wood Chunks | Internal Temp |
|--------------------|---------------|------------------|------------------------|---------------------|--------------------|---------------------------|
| Small whole | Full grill | Full | 1 | 1 ½ - 3 hrs. | 2-4 | Flakes with a fork. |
| Fillets | Full grill | Full | 1 | 1 ½ - 3 hrs. | 2-4 | |
| Large whole | 3-6 lbs. | Full | 1 | 3-4 hrs. | 2-4 | |
| Lobster, Shrimp | Full grill | Full | 1 | 1 hr. | 2-4 | firm/pink |

Pork Roast

- 1 rolled pork loin roast, 5-6 lbs.
- 1 garlic clove, cut into slivers
- ½ teaspoon celery salt
- ½ teaspoon rosemary
- ½ teaspoon sweet basil
- ¼ teaspoon pepper
- 1 teaspoon caraway seed

Make small slits in top of roast and insert a garlic sliver in each slit. Combine seasonings and sprinkle over roast. Place meat in center of cooking grill. Cover and smoke-cook about 6 hours or until done.

Barbecued Pork Roast

- 4 lbs. pork back ribs or spareribs
- ¼ cup molasses
- ¼ cup Soy sauce
- ¼ cup vinegar
- ½ cup prepared mustard
- 2 teaspoons Worcestershire sauce
- ½ teaspoon hot pepper sauce (more if desired)

Place ribs in a plastic or glass dish. Combine remaining ingredients and pour over ribs. Cover and refrigerate 5 hours or overnight. Turn ribs occasionally to completely coat with marinade. Remove ribs from marinade and place on the cooking grill or in a rib rack. Cover and smoke-cook 4½ to 5 hours or until done.

Pork Tenderloin Tarragon

- 2 whole pork tenderloins
- ½ cup white tarragon vinegar
- 1 teaspoon Worcestershire sauce
- 2 teaspoons soy sauce
- 1 teaspoon dried tarragon

Place pork tenderloins in a shallow glass or plastic dish. Combine remaining ingredients and pour over meat. Cover with plastic wrap and refrigerate 3 to 4 hours. Turn meat in marinade occasionally. Place pork tenderloins on cooking grill. Pour marinade over meat allowing excess to drain into the water pan. Smoke-cook 3 to 4 hours. Serve with pineapple sauce.

Pineapple Sauce:

Combine equal parts of drained crushed pineapple and sour cream.
Approximately 8 oz. of each.

Smoked Glazed Ham

- 1 fully cooked ham, 10-14 lbs.
- Whole cloves
- 1 quart apple cider

Remove any rind left on ham and score fat diagonally to give a diamond effect. Insert a whole clove in center of each diamond. Place ham fat side up on cooking grill. Pour apple cider over ham allowing excess to go into water pan. Cover and smoke-cook 3-4 hours brushing with glaze occasionally during the last hour of cooking time.

Glaze

- 1 – 9 oz. jar currant jelly
- ¼ cup orange juice concentrate, undiluted
- 1 teaspoon prepared horseradish
- 1 teaspoon dry mustard
- 1 teaspoon lemon juice

Combine all ingredients in a saucepan. Heat, stirring until jelly melts.

Smoked Fresh Ham

- 1 fresh ham, 6-7 lbs.
- Sweet pickle Brine (page 7)
- Brown sugar

Prepare sweet pickle brine. Brine ham for 3 days in brine. Remove from brine. Rinse ham in cold water and pat dry with paper towel. Let ham dry in refrigerator for 1 day. Rub outside surfaces of ham with brown sugar. Place ham in center of cooking grate. Cover and smoke approximately 8 hours. May be served immediately, however, flavor is enhanced by refrigerating a day or two before serving.

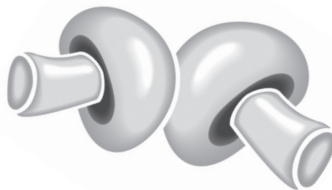

Beef Ribs

- 2-3 lbs. beef back ribs
- 2 – 8 oz. cans tomato sauce
- ¼ cup red wine vinegar
- 2 tablespoons prepared mustard
- 1 tablespoon prepared horseradish
- 1 tablespoon instant minced onion
- ½ teaspoon garlic powder
- ¼ teaspoon pepper

Place ribs in a shallow glass or plastic dish large enough to accommodate them in a single layer. Combine remaining ingredients and pour over ribs. Turn meat over to completely coat with marinade. Cover with plastic wrap and refrigerate at least 4 hours turning occasionally. Remove ribs from marinade and place on cooking grill. Pour remaining marinade over ribs allowing excess to drain into water pan. Smoke-cook 3½ to 4 hours.

Beef Brisket

- 1 beef brisket, 5-6 lbs.
- 1 envelope dry onion soup mix
- 2 tablespoons port wine
- 2 cups barbecue sauce

Combine soup mix and wine to make a paste. Spread over surface of the brisket. Allow brisket to stand at room temperature 2 hours before cooking. Add barbecue sauce to the water in the water pan. Position brisket in center of cooking grill. Cover and smoke-cook approximately 6 hours or until tender.

Glazed Meat Loaf

- 1½ lbs. lean ground beef
- ½ cup soda crackers, coarsely crumbled
- ½ cup onion, finely chopped
- 2 eggs, slightly beaten
- 1 teaspoon salt
- ½ teaspoon garlic salt
- ½ teaspoon paprika
- ¼ teaspoon pepper
- ¾ cup milk
- 1½ cups sharp cheddar cheese, cubed
- 2 slices bacon

Combine ground beef, crumbs, onion and seasonings in a large bowl. Add eggs, milk and cheese cubes; mix lightly until blended. Turn mixture into an aluminum foil pan and shape into a loaf. Place bacon slices lengthwise on top of meat loaf. Position foil pan with meat loaf in center of cooking grill. Smoke-cook 4 hours or until top of loaf feels firm.

Glazed Hickory Smoked Turkey

1 turkey, thawed, 8-10 lbs.
Seasoned salt
1 tablespoon paprika

Stuffing:

2 oranges, cut into 8 chunks
Large onion, cut into 8 chunks
2-3 ribs celery, cut into 1" pieces

Glaze:

½ cup currant jelly
½ cup port wine

Combine currant jelly and wine in a saucepan and cook over medium low heat stirring constantly until jelly is melted. If glaze gets too sticky during use, reheat it.

Rinse turkey thoroughly with cold water. Pat bird dry. Season inside and outside with seasoned salt. Sprinkle outer surface with paprika. Stuff turkey with orange, onion and celery chunks alternating the three different items. Fasten neck skin over back with skewer; lock together. Place turkey on cooking grill. Cover with wine-jelly glaze during the last 2 hours of cooking time.

Smoked Duck

1 duckling, thawed, 5 lbs.
6 green onions with tops, cut up
4-5 sprigs parsley
1 clove garlic, minced
½ cup soy sauce
2 tablespoons lemon juice
2 tablespoons honey

Rinse bird thoroughly with cold water, drain and pat dry with paper toweling. Stuff cavity of duckling with onion, parsley and garlic. Use a sharp knife to make a small cut between the wing joints and breast to permit draining of excess fat during cooking. Lock wings behind back and tie legs and tail together. Fasten neck skin over back with a skewer. Heat soy sauce, honey and lemon juice, in a saucepan, to make a glaze. Place duckling in center of cooking grill. Cover and smoke-cook 5-6 hours until done. Brush duckling with glaze occasionally. Serve with plum sauce.

Plum Sauce

1 – 16 oz. can purple plums
¼ teaspoon orange peel, grated
3 tablespoons orange juice
2 tablespoons sugar
¼ teaspoon cinnamon
½ teaspoon Worcestershire sauce

Drain plums reserving ¼ cup syrup. Force plums through a sieve. Combine plum puree and reserved plum syrup with remaining ingredients in a saucepan. Heat to boiling; reduce heat and simmer 15 minutes.

Cornish Hens

2 to 4 Cornish game hens, about 1 lb. each

Seasoned salt

Lemon pepper

1 large carrot, cut into julienne strips

1 medium onion, cut into wedges

Madeira Wine Sauce

Wash Cornish hens thoroughly with cold water and pat dry with paper toweling. Season inside with seasoned salt and lemon pepper. Put carrot strips and onion wedges inside each hen. Lock wings behind the back and tie legs together securely. Wrap a bacon strip around each hen and secure with a toothpick. Sprinkle with lemon pepper and seasoned salt. Place hens on cooking grill. Cover and smoke-cook 3 hours or until done. Baste with Madeira wine sauce during last 15 minutes of cooking time. Serve with remaining sauce.

Madeira Wine Sauce

1 cup crabapple jelly

½ teaspoon ginger

¼ teaspoon salt

¼ cup Madeira Wine

1 orange peeled, cut orange peel into 3" julienne strips

Combine jelly, ginger, salt and wine. Cook over low heat until jelly melts; add orange strips and simmer for 2 minutes.

Smoked Turkey

1 turkey, 12 lbs. completely thawed

Sweet Pickle Brine (see page 7)

Maple syrup

Rinse turkey thoroughly with cold water, drain and pat dry. Prepare sweet pickle brine. Brine 12 lb. turkey for 3 days. Remove from brine, rinse thoroughly in cold water and pat dry. Allow to dry in refrigerator for 24 hours. Lock wings behind back and tie legs and tail together. Baste bird with maple syrup before putting in the smoker and every 2 hours during smoking. Position turkey on cooking grill. Smoke-cook 7 hours or until done. Cool turkey in the refrigerator for 24 hours before serving to enhance the smoked flavor. Turkey may be served immediately if you wish.

Brine:

8-12 lb. bird — 3 days

13-16 lb. bird — 4 days

17-22 lb. bird — 5 days

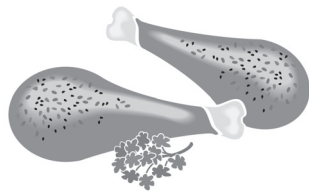

Smoked Whole Chicken

1 whole broiler-fryer chicken, 2½-3 lbs.

Seasoned salt

White wine (optional)

Wash chicken thoroughly with cold water and pat dry with paper toweling. Lock wings behind back and tie legs together securely. Sprinkle seasoned salt generously on chicken. Pour white wine into water pan. Cover and smoke-cook 3 hours.

Fish

Any edible saltwater or freshwater fish can be smoked. If you wish, fish may be smoke-cooked without curing, or they can be cured before smoking with either a dry cure or in a brine. Grills in the smoker should be lightly oiled to prevent fish from sticking. Fish may be placed in an aluminum foil pan or on a sheet of aluminum foil, which have been lightly oiled. Fish should be checked occasionally during cooking time because some of them tend to dry out rapidly and may require basting—brushing with cooking oil will help to keep them moist. If you prefer fish dry—allow it to remain in the smoker for an extra hour or two after it is done. When fish flakes easily with a fork it is done.

To prepare fish for cooking: thoroughly rinse exterior in fresh, cold water; remove scales and internal organs; thoroughly clean the body cavity. Small fish can be left whole. Large fish may be left whole or cut into smaller pieces. Use short sticks to wedge crosswise inside split fish to hold the cavity open while smoking so the smoke can circulate inside the fish.

Smoked Whole Fish

1 large whole fish, 8 to 10 lbs., cleaned

Red Snapper, Salmon, Trout or Sea Bass

½ cup lemon juice

1 tablespoon Worcestershire sauce

1 tablespoon prepared mustard

½ teaspoon basil

½ teaspoon garlic salt

½ teaspoon salt

1 medium onion, thinly sliced

1 lemon, thinly sliced

Melted oil or butter

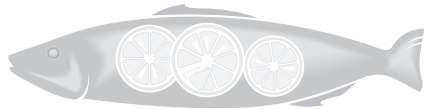

Combine lemon juice, Worcestershire sauce, prepared mustard, basil and salts; mix and brush in cavity of fish. Arrange ½ of the onion and lemon slices alternately in a row in cavity of fish. Brush outside of fish with melted oil or butter. Overlap remaining onion and lemon slices on top of fish. Place fish on cooking grill. Drizzle remaining lemon juice mixture over the fish allowing excess to go into the water pan. Cover and smoke-cook 3-4 hours or until done.

Halibut Steak

4 Halibut steaks, $\frac{3}{4}$ " thick
 $\frac{1}{4}$ cup butter or margarine, melted
 Juice of 1 lemon
 Salt and pepper
 Worcestershire sauce

If halibut is frozen, thaw. Grease an aluminum foil tray. Place steaks in tray and pour melted butter over them. Squeeze lemon juice on steaks. Sprinkle with salt, pepper and Worcestershire. Place foil tray on cooking grill. Cover and smoke-cook until the fish flake easily when tested with a fork, approximately 1 hour.

Whole Pan Fish

6 small whole pan fish, cleaned
 1 teaspoon salt
 $\frac{1}{2}$ teaspoon pepper
 Juice of 1 lemon
 3 bacon slices, halved

If fish are frozen, thaw. Clean and dry fish. Sprinkle cavities with lemon juice, salt and pepper. Brush outside of fish with oil. Place a half strip of bacon lengthwise on top of each fish. Arrange fish on the cooking grill and smoke-cook 1 to 1 $\frac{1}{2}$ hours or until they flake when tested with a fork. Serve with lemon butter.

Lemon Butter:

1 cup softened butter or margarine
 $\frac{1}{4}$ cup lemon juice
 1 tablespoon minced parsley
 $\frac{3}{4}$ teaspoon grated lemon peel
 $\frac{1}{4}$ teaspoon salt

Combine all ingredients.

Smoked Lobster Tail

Lobster tails, thawed (1 per person)
 Melted butter
 Lemon wedges

Cut away underside membrane on lobster. To prevent curling while cooking, hold lobster tail in both hands and bend backward to crack the shell. Brush with melted butter and position on the cooking grill. Cover and smoke-cook about 1 hour or until flesh is white and firm. Serve with melted butter and lemon wedges.



Smoke Flavoring

Introduce family and friends to a new flavor treat—try smoking cheese, nuts and eggs. This should be done at a low degree of heat—the best time to do smoke flavoring is after you have smoke-cooked something and the coals have burned down and are producing a low heat.

NUTS

Any kind of nuts or seeds can be smoke flavored for a tasty snack. Place nuts in a single layer, on a wire screen, on top of the cooking grill. Place 3-4 wet chunks of wood on top of coals. Smoke for 45-60 minutes. (Do not use water in water pan.)

CHEESE

Any mild-flavored cheese may be given a smoke flavor; try Colby, Monterey Jack or Muenster. Make a shallow tray of extra-heavy duty aluminum foil or use a shallow foil pan. Place cheese in tray and position on the cooking grill. Place 3-4 chunks of wet wood on top of the coals. Smoke about 1 hour. Make sure the fire is not too hot, watch carefully so the cheese doesn't melt. (Do not use water in the water pan.)

EGGS

Chilled, peeled hard-cooked eggs. Arrange eggs on the cooking grill. Place 3-4 chunks of wet wood on top of the coals. Smoke 25-30 minutes or until lightly browned. Remove eggs from smoker and serve immediately or wrap in plastic wrap and refrigerate. Great for deviled eggs!

NOTE: We used hickory or apple wood for smoke flavoring and soaked it in water for 45-60 minutes before using. Experiment—perhaps you will find a different type of hardwood you like better.



Barbecuing

Position the charcoal grate and charcoal chamber as shown in step 8 (pg. 9) of this book. Pour charcoal one layer deep on charcoal grill. Heap charcoal in center of grill. Ignite charcoal. When coals have a light coating of gray ash (approximately 30 minutes) spread them one layer deep again. Put cooking grill in place on the top bracket. Place meat on the cooking grill. Cover smoker. All vents should be wide open.

This method of cooking is used for fast cooking of flat meats. Food is cooked on one side and must be turned to expose both sides of the meat to the heat.

Steak

Rib, T-bone, Club, Porterhouse,
Sirloin or Filet, $\frac{3}{4}$ - 1 lb. per person
Salt and pepper

To prevent steak from curling during cooking slit fat at $1\frac{1}{2}$ - 2 inch intervals. Refer to steak cooking chart below for cooking times. Cover steaks when cooking. Covering helps to eliminate flare-ups. If you prefer searing steak, leave cover off for the first minute or two on each side. Use meat tongs when turning steak to prevent piercing and loss of natural juices.

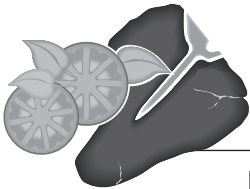

STEAK COOKING CHART

| Steak Thickness | RARE | MEDIUM | WELL- DONE |
|-----------------|--------------------|--------------------|--------------------|
| | 1st side /2nd side | 1st side /2nd side | 1st side /2nd side |
| 1" | 2 min./3 min. | 4 min./4 min. | 5 min./6 min. |
| 1½" | 5 min./6 min. | 7 min./8 min. | 9 min./10 min. |
| 2" | 7 min./8 min. | 9 min./9 min. | 10 min./11 min. |

Hamburgers

- 1 lb. ground beef, lean
- $\frac{1}{4}$ teaspoon black pepper
- $\frac{1}{4}$ teaspoon salt
- $\frac{1}{4}$ teaspoon dried minced onions or 1 tablespoon minced fresh onion

Combine all ingredients, mix well. Shape into 4-6 patties on cooking grill and follow cooking times given below. Cover hamburgers while cooking. This helps to eliminate flare-ups. Always use a spatula or tongs when turning patties to prevent piercing and loss of natural juices. If you prefer searing patties, leave cover off for first minute on each side.

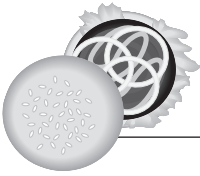

BURGER COOKING CHART

| | RARE | MEDIUM | WELL- DONE |
|-----------------|--------|--------|------------|
| Per side | 3 min. | 4 min. | 5 min. |

Gyro Burgers

- 1 lb. ground chuck
- 1 lb. ground lamb
- 1 egg
- $\frac{1}{4}$ cup water
- $\frac{1}{2}$ cup bread crumbs
- $\frac{1}{4}$ teaspoon garlic powder
- $\frac{1}{4}$ teaspoon cinnamon
- $\frac{1}{4}$ teaspoon allspice
- $\frac{1}{2}$ teaspoon thyme
- $\frac{1}{2}$ teaspoon sweet basil
- 2 teaspoons oregano

Combine all ingredients; mix well. Shape into patties $4 \frac{1}{2}$ " diameter $\frac{1}{2}$ inch thick. Place patties on cooking grill and cook 4 min. on each side. Serve on a hamburger bun or Pita bread (pocket bread) with chopped lettuce, sliced onions, tomato and yogurt sauce.

Yogurt Sauce:

- 1 cup yogurt
- 5 tablespoons sour cream
- 2 tablespoons parsley flakes
- $\frac{1}{4}$ cup cucumber, chopped
- $\frac{1}{4}$ cup onion, chopped

Mix all ingredients together; refrigerate. Spoon onto Gyro burgers before serving.

Brats-in-Beer

1 can beer, 12 oz.
6 bratwurst

Pour beer into an aluminum foil pan large enough to hold brats in one layer. Place pan of beer on one side of cooking grill. Brown brats on cooking grill watching carefully turning as necessary to brown evenly. When brats are brown; place in beer. Cover smoker and cook 25 minutes.

Kabobs

Any combination of foods that will go onto a skewer can be tried as kabobs. Use your imagination and try different combinations—do fruit or vegetable kabobs for an unbeatable flavor addition to your brunch or dinner menu; or combine meat or seafood with vegetables for a delicious entree. Keep in mind that if you choose foods that require similar cooking times everything will be done at the same time. Use less charcoal when preparing fire for kabob cooking. The coals should be sparsely spaced so heat is not too intense.

Land and Sea Kabobs

¼ cup lemon juice
1 envelope onion soup mix
¼ cup soy sauce
¼ cup vegetable oil
1 can pineapple chunks, 8 oz., drained—reserve liquid
½ lb. sirloin steak, cut into 1" cubes
½ lb. shrimp, peeled and deveined
16 cherry tomatoes
8 mushroom caps
1 green pepper, cut into 1" squares

Combine first four ingredients plus reserved pineapple liquid in non-metal bowl. Add beef cubes; stir meat to coat completely. Cover; refrigerate at least 3 hours. Add shrimp to beef mixture and refrigerate 1 hour longer. Arrange ingredients alternately on skewers. Place kabobs on cooking grill and cook approximately 15 minutes. Turn occasionally and baste with marinade.

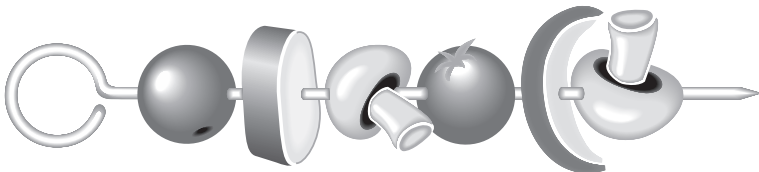

Steaming

Position the charcoal grate and charcoal chamber as shown in step 8 (pg. 9) of this book. Fill the charcoal chamber about 1/2 full with charcoal, arrange the charcoal so it will conform to the shape of the water pan (higher on sides and lower in center). When the coals are ash gray place the water pan on top of the charcoal chamber; add boiling water (approximately 4 quarts). Seasonings or marinades may be added to the water for additional flavor. Place the no-handled cooking grate on top of the water pan; add meat. Place cover on smoker. Top vent should be closed, bottom vents open while steaming.

Lobster Tails

Lobster tails (1 per serving)
Melted butter
Seasoned salt

If using frozen lobster allow it to thaw; cut away underside membrane. To prevent curling while cooking, hold tail in both hands and bend backward to crack the shell. Brush with melted butter and sprinkle with seasoned salt. Place on the cooking grill and steam 20 minutes or until shell is bright red.

Clams

Scrub clams under running water until free of sand. Place clams on cooking grill. Cover and steam until shells open. Approximately 15 minutes.

Shrimp

1 lb. fresh shrimp, peeled, cleaned and deveined, ready to cook
¼ cup butter, melted
Juice of ½ lemon
1 clove of garlic, crushed
¼ teaspoon oregano
¼ teaspoon sweet basil

Combine butter with lemon juice, garlic and seasonings. Pour over shrimp and marinate for at least ½ hour. Remove shrimp from marinade. Large shrimp can be placed directly on the cooking grill. If shrimp are small lay them on a piece of aluminum foil that has been punctured with a fork. Steam approximately 15 minutes or until pink and tender.



Weber-Stephen Products Co., (Weber) hereby warrants to the ORIGINAL PURCHASER of this Weber® One-Touch® Silver, One-Touch® Gold, One-Touch® Platinum, Smokey Mountain Cooker®, and Ranch® grills, that it will be free from defects in material and workmanship from the date of purchase as follows:

| | |
|--|---------------------------|
| Cooking / Charcoal grates | 1 year |
| Stainless Steel One-Touch® Cleaning System (One-Touch® Platinum) | 10 years |
| Bowl and lid against rust / burn-through | 10 years |
| Nylon handles | 10 years |
| Thermoplastic/Thermoset Parts(One-Touch® Platinum) | 10 years excluding fading |
| All remaining parts | 5 years |

When assembled and operated in accordance with the printed instructions accompanying it. Weber may require reasonable proof of your date of purchase. THEREFORE, YOU SHOULD RETAIN YOUR SALES SLIP OR INVOICE AND RETURN THE WEBER LIMITED WARRANTY REGISTRATION CARD IMMEDIATELY. This Limited Warranty shall be limited to the repair or replacement of parts which prove defective under normal use and service and which on examination shall indicate to Weber's satisfaction they are defective. If Weber confirms the defect and approves the claim, Weber will elect to repair or replace such parts without charge. If you are required to return defective parts, transportation charges must be prepaid. Weber will return parts to the purchaser, carriage or postage prepaid.

This Limited Warranty does not cover any failures or operating difficulties due to accident, abuse, misuse, alteration, misapplication, vandalism, improper installation or improper maintenance or service, or failure to perform normal and routine maintenance. Deterioration or damage due to severe weather conditions such as hail, hurricanes, earthquakes or tornadoes, discoloration due to exposure to chemicals, either directly or in the atmosphere, is not covered by this Limited Warranty.

There are no other express warranties except as set forth herein, and any applicable implied warranties of merchantability and fitness are limited in duration to the period of coverage of this express written Limited Warranty. Some regions do not allow limitation on how long an implied warranty lasts, so this limitation may not apply to you.

Weber is not liable for any special, indirect or consequential damages. Some regions do not allow the exclusion or limitation of incidental or consequential damages, so this limitation or exclusion may not apply to you.

Weber does not authorize any person or company to assume for it any other obligation or liability in connection with the sale, installation, use, removal, return or replacement of its equipment; and no such representations are binding on Weber.



WEBER-STEPHEN PRODUCTS CO.
www.weber.com®

©2003 The following trademarks are registered in the name of Weber-Stephen Products Co., an Illinois corporation, located at 200 East Daniels Road, Palatine, Illinois 60067 U.S.A. Australia; Smokey Joe, Weber, Kettle Silhouette®, Genesis, Austria; Kettle Silhouette®, Smokey Joe, Weber, Benelux; Kettle Silhouette®, Smokey Joe, Weber, Compact Grill Configuration, Botswana; Weber, Canada; Smokey Joe, Genesis, China; Kettle Silhouette®, Denmark; Kettle Silhouette®, Smokey Joe, Weber, Finland; Smokey Joe, France; Kettle Silhouette®, Smokey Joe, Weber, One-Touch, Germany; Smokey Joe, Weber, One-Touch, Greece; Smokey Joe, Ireland; Kettle Silhouette®, Smokey Joe, Italy; Smokey Joe, Weber, Japan; Smokey Joe, Weber, Korea; Smokey Joe, Weber, New Zealand; Weber, Smokey Joe, Nigeria; Weber, Norway; Smokey Joe, Weber, Portugal; Weber, South Africa; Smokey Joe, Weber, Kettle Configuration, Spain; Smokey Joe, Weber, Sweden; Kettle Silhouette®, Smokey Joe, Switzerland; Kettle Silhouette®, Smokey Joe, Weber, United Kingdom; Smokey Joe, Weber, Weber One-Touch, U.S.A.; Kettle Configuration, Kettle Silhouette®, Smokey Joe, Weber, One-Touch, Firespice, Go-Anywhere, U.S.A.; Kettle Configuration, Kettle Silhouette, Genesis, Flavorizer, Crossover, Flamgo, Performer, Rapidfire, Tuck 'N Carry, Jumbo Joe, Bar-B-Kettle, Master-Touch, Spirit, Grill Out, Summit, Platinum, 1-800-Grill-Out, Ranch, Matchless Flame, Zimbabwe; Weber, Kettle Configuration, Kettle Silhouette®.